

HOT WATER CIRCULATING SYSTEM

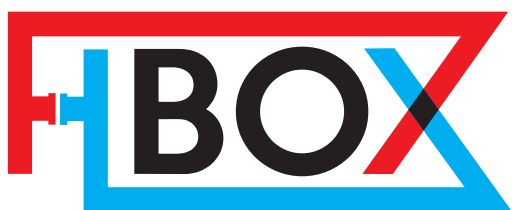

Designed to overcome limitations of hot water circulation in systems utilising hot water meters and/or pressure control valves in centralised risers.

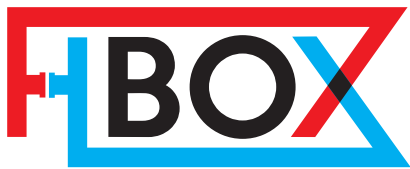

Hot Water Circulating Systems

“H-box” units are a range of systems designed to facilitate hot water circulation in plumbing systems in order to maintain the water temperature in pipes, specifically where traditional hot water circulating systems cannot be used due to design constraints relating to circulating hot water through water meters or pressure control valves as often encountered in multi-level buildings.

The H-box is available in “multi-zone” models for use in applications where the product maintains hot water to individual apartment units, and is also available in “single zone” models which can be used to bypass pressure control valve stations in risers or floor branches to maintain temperatures in the main circulating rings.

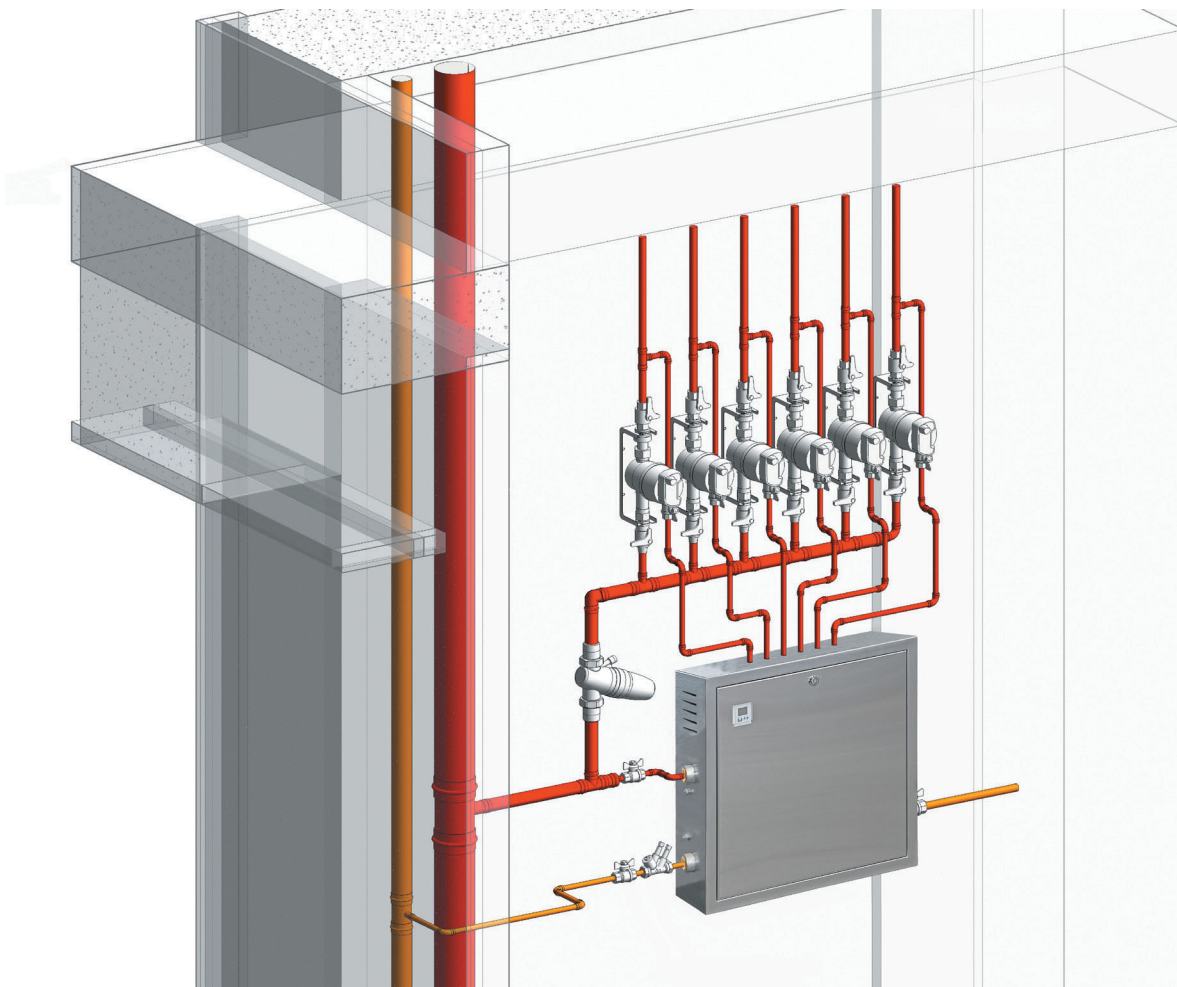

H-BOX MULTI ZONE Background

Circulating hot water in a plumbing system to maintain the design temperature is standard practice in most residential and commercial multi-level buildings with the hot water generally being circulated vertically from the hot water plant down (or up) the building. If hot water needs to be delivered to fixtures far from the central riser, then the delivery time can be substantial and also wastes cold water.

From the vertical riser, it is ideal to branch off and circulate hot water on each floor close to the apartments and fixtures, however, if a hot water meter is installed in a common central cupboard as required by some water authorities or utilities then circulating hot water becomes an issue as any water passing through the meter is charged as consumption, therefore circulating systems cannot be utilised which instead can potentially create very long dead legs and long wait times for hot water delivery.

In addition, adopting a centralised water pressure control station design within the meter cupboard creates a low pressure zone after the valves which also prohibits circulation to the apartments.

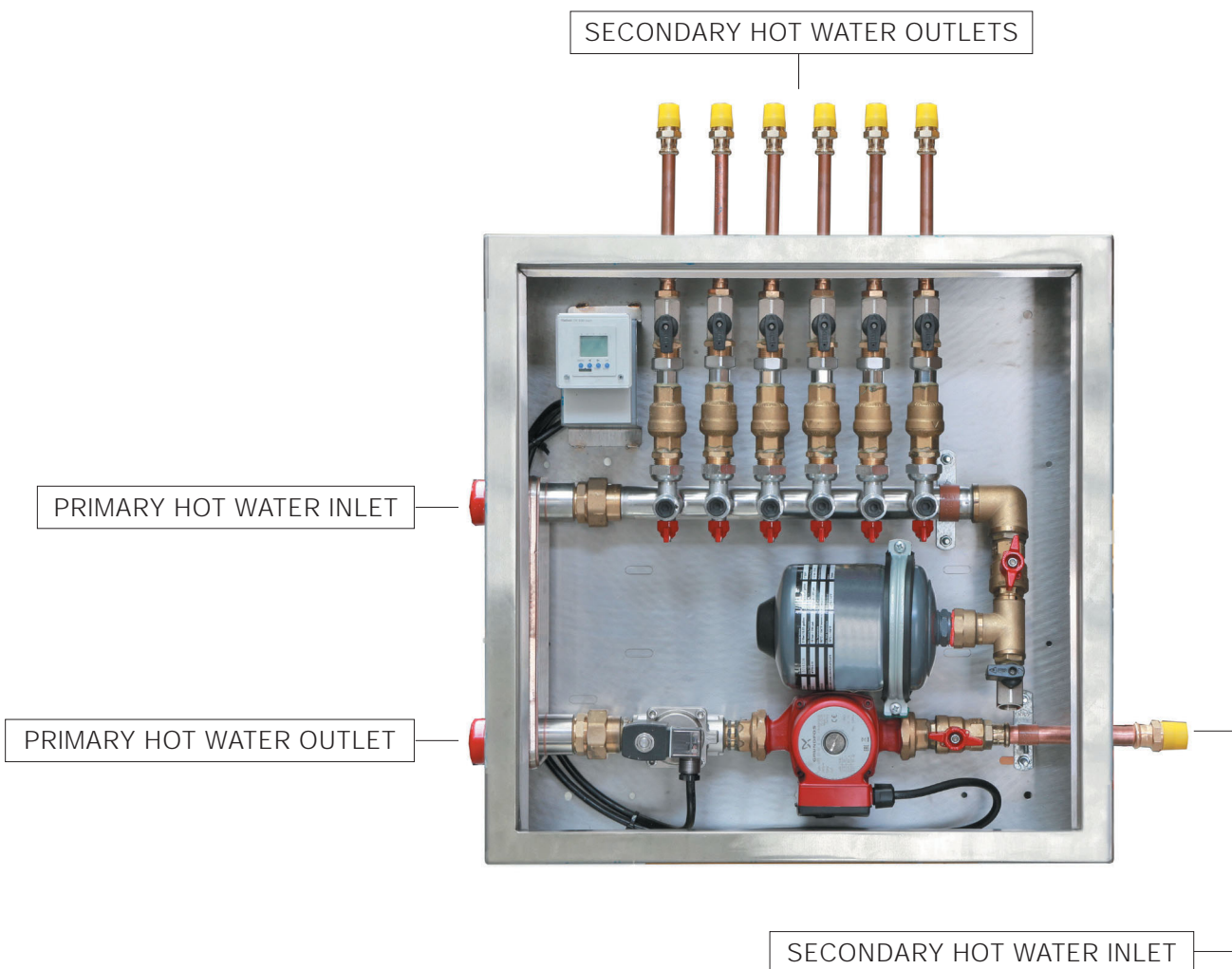

Current Solutions

The current most common solution is to use electric heat trace to maintain temperature in these dead legs, or alternatively increase the number of risers in the building. Both options have numerous hindrances with regards to cost, performance or implementation issues which can be improved utilising the H-Box solution. To achieve this, a special new 'auto-stop' valve was designed which automatically isolates the relevant circuit when a pressure differential is created from using hot water.

H-box Multi Zone solution

The new H-box Multi Zone solution is a patented system which is installed after the water meters on each level to circulate hot water to the apartments on that floor. It is a pre-assembled unit comprising of a heat exchanger, pump, digital timer, expansion tank, new specially designed 'auto-stop' valves as well as all other relevant components to ensure the system operates correctly.

The heat exchanger transfers heat from the primary central vertical riser, to a secondary circulating system for each floor serving multiple apartments. Utilising a heat exchanger and pump is not new, however, the issue with using a common circulating system for multiple apartments is that when a user opens a tap fixture, some hot water would inadvertently be drawn from another user's hot water supply, rather than their own. To prevent cross connection of this type, it is necessary to isolate each individual unit from the rest of the circulating system during the time of hot water consumption. To achieve this, a special new 'auto-stop' valve was designed which automatically isolates the relevant circuit when a pressure differential is created from using hot water.

Utilising H-box solution, the hot water delivery time is reduced to an average of 3 – 8 seconds for most installations when designed in accordance with our recommendations.

Benefits

BENEFITS OF H-BOX OVER HEAT TRACE

Plumber

- ◆ Installation wholly by the plumber, whereas heat trace is to be installed by a licensed electrician*
- ◆ Pex and other soft pipes may be used
- ◆ Fire rating the penetrations isn't required

Builder / developer

- ◆ More cost effective than heat trace
- ◆ Less co-ordination between electrician and plumber

Home owner

- ◆ Lower running costs
- ◆ Much faster response time to heat up the circuits
- ◆ Reduced water wastage
- ◆ Improved HW delivery time of just a few seconds.
Average delivery time using heat trace is 10-20 seconds.

BENEFITS OF H-BOX OVER MULTIPLE RISERS

Plumber

- ◆ Less risers, manifolds, PRVs, etc required

Builder / developer

- ◆ Usually more cost effective than multiple risers
- ◆ Less space required thereby maximising saleable space.

Home owner

- ◆ Improved HW delivery time of just a few seconds.
Average delivery time using multiple risers is up to 15-30 seconds or more.

WATER SAVINGS HAVE POTENTIAL TO IMPROVE BASIX WATER SCORE - PENDING CONFIRMATION FROM BASIX

* An electrical licence is required before any electrical wiring and installation work can be undertaken in NSW, regardless of cost of the work and regardless of whether the work is residential, commercial or industrial.
(<https://www.fairtrading.nsw.gov.au/trades-and-businesses/licensing-and-qualifications/licence-classes-and-qualifications/electrical>)

H-box Multi Zone System Operation

Hot water circulates from the central hot water plant through the building via the primary vertical riser pipes and back to the hot water plant. Hot water may be drawn off from the central hot water system through the main floor branch and hot water meters to the units, like any normal system.

If no water is being drawn off, then the circuits after the hot water meters should be kept hot to reduce the time taken for hot water delivery and to reduce water wastage. The H-box is installed which, via the heat exchanger, transfers heat from the primary central heating riser pipes to the secondary circuit and uses a pump to circulate the heated water to the units and back to the H-box via a common return.

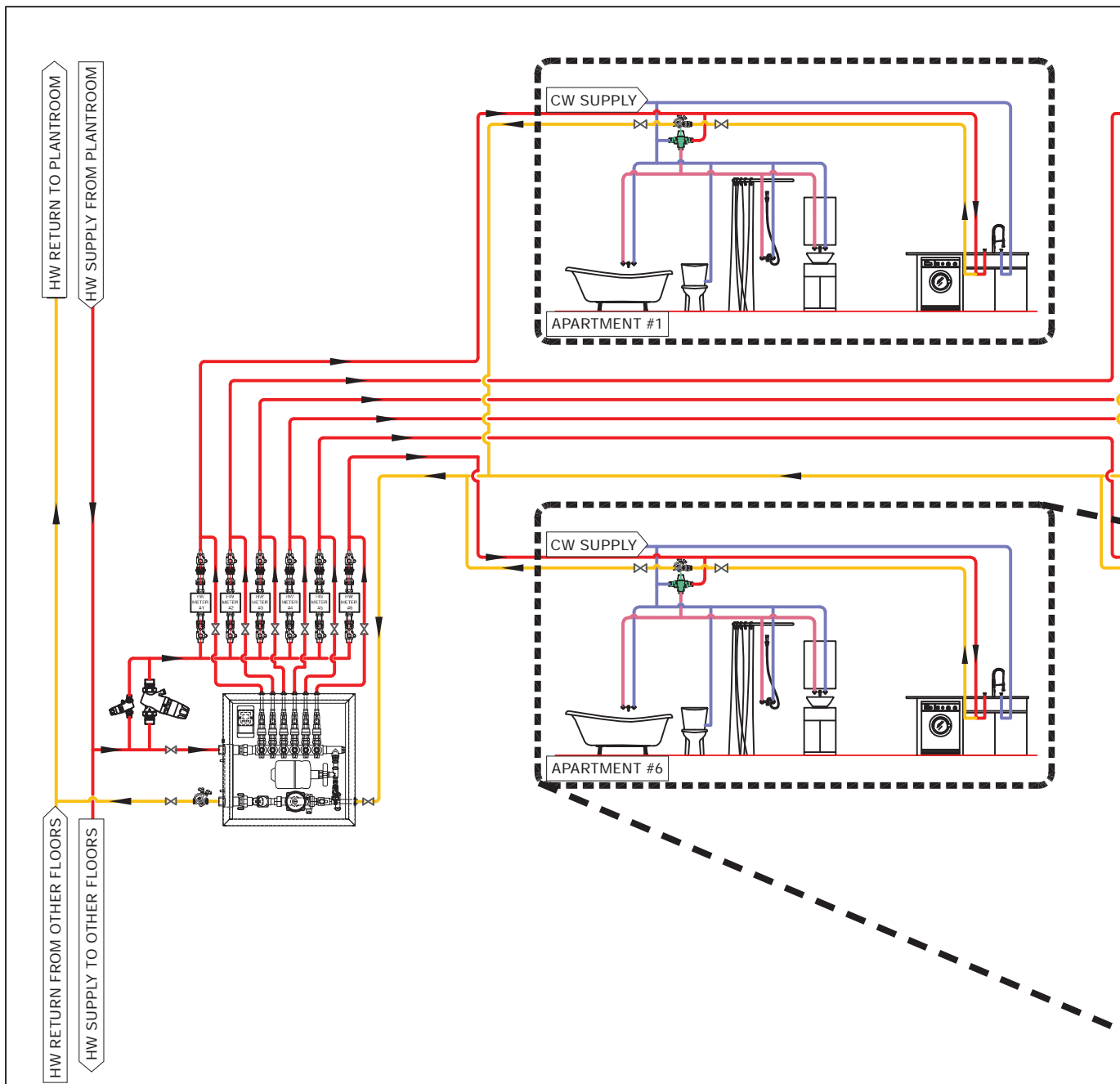

In order to achieve the correct flow rates required by the system, an automatic balancing valve is installed on the return lines after each apartment to balance flow rates to a predetermined value in each circuit of the secondary side. The automatic balancing valves are pre-set and supplied as part of the H-box packaged solution.

In the event of hot water being drawn off from a fixture within a unit, the H-box will isolate that particular circulation circuit serving that unit so that all water is being drawn from the central heating system and through the hot water meter and not from the H-Box system.

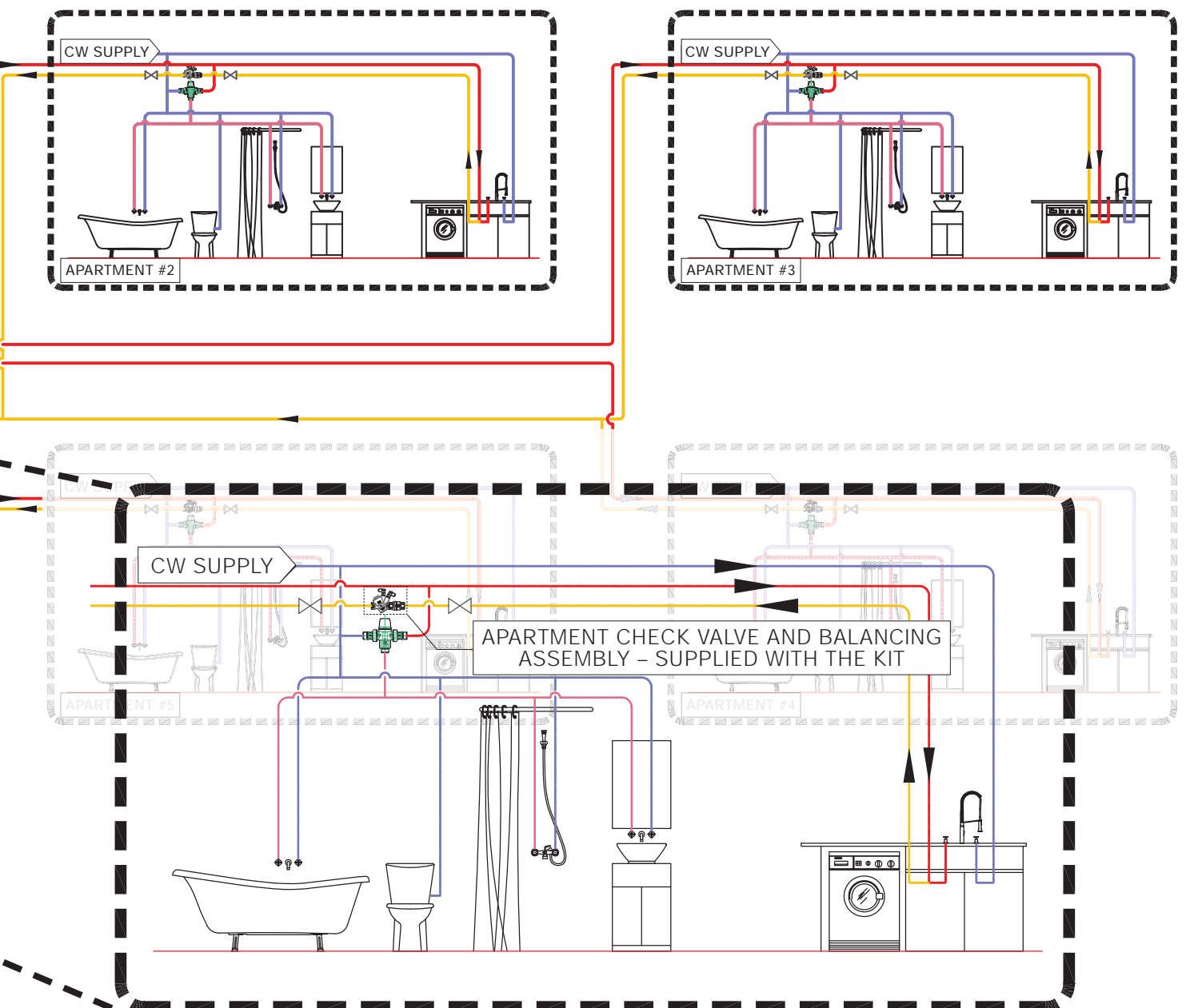

Design guide

General

- ◆ The riser is preferred to be positioned as central as possible within the building.
- ◆ Each HW riser requires a dedicated return line as the H-box requires connection to both flow and return risers.
- ◆ Gas meters need to be installed in a separate cupboard due to the electrical supply, as per Gas Code.
- ◆ All circulating pipes must be rated to a minimum of 70°C and rated for 24H continuous circulation.

Primary Side

Simple method

- ◆ Calculate the flow rate of the primary circuit based on 3°C max temperature drop: (Q_1).
- ◆ Calculate the total flow rate required by all H-box units based on minimum recommend flow rates per H-box (0.08 l/s for H-box6 and 0.1 l/s for H-box10): (Q_2).
- ◆ Flow rate of system is MAX [Q_1 , Q_2]
- ◆ Allow for a minimum 15kPa pressure loss across the H-BOX on the index circuit when calculating the pump head required on the HW plant circulation pumps

Detailed Method

- ◆ For each H-BOX, add up the heat losses of all the apartment circulation pipes served by that H-BOX.
- ◆ Calculate the flow rate required for each H-BOX based on a 5°C max temperature drop.
This flow rate should be specified at time of order as it will be set on the primary side automatic balancing valve supplied with the system.
- ◆ Calculate the flow rate required in the remaining primary system, including riser pipes, ring mains and return lines based on a 5°C max temperature drop
- ◆ Total the flow rate required of each H-BOX with the flow rate of primary system to obtain the total system flow rate.
- ◆ Allow for a minimum 15kPa pressure loss across the H-BOX on the index circuit when calculating the pump head required on the HW plant circulation pumps

Contact All Valve Industries for assistance in sizing the primary side flow rate and balancing valve selection if required. Ensure that the hot water return riser to the hot water plant and the hot water circulating pumps are adequately sized based on the calculated circulation flow rates.

Secondary Side

The H-BOX multi zone system has been designed to accommodate most average sized building footprints. All sizing, flows rates, temperature losses, etc have been calculated for the system to operate effectively and the H-box is designed for 'plug and play' installation.

It is suggested to limit the length of each apartment loop to maximum of 40 metres, which includes the flow pipe from the H-BOX to the unit, and the section of return pipe from the last fixture within the apartment to where it joins the common return.

Tempering valve(s) must be located within the apartment on a branch off the hot water circulating loop. It is suggested that each bathroom is installed with a dedicated tempering valve to maximise the benefit of the HW delivery time offered by the H-BOX solution.

Supply and return lines to/from apartments to be lagged in accordance with AS3500.4 to minimise heat-loss. Insulation should be installed on all circulating pipes to a rating of at least R0.6, with a recommended value of R1.0.

A preassembled automatic balancing valve kit is supplied for each apartment served by the H-BOX system. This balancing valve should be installed anywhere on the apartment return line, somewhere between the last fixture and the point at which it connects to the common return line. This assembly is to be located in an accessible area in case of maintenance, and if possible, it should ideally located in a common area.

Image of Apartment Balancing valve kit is shown below.

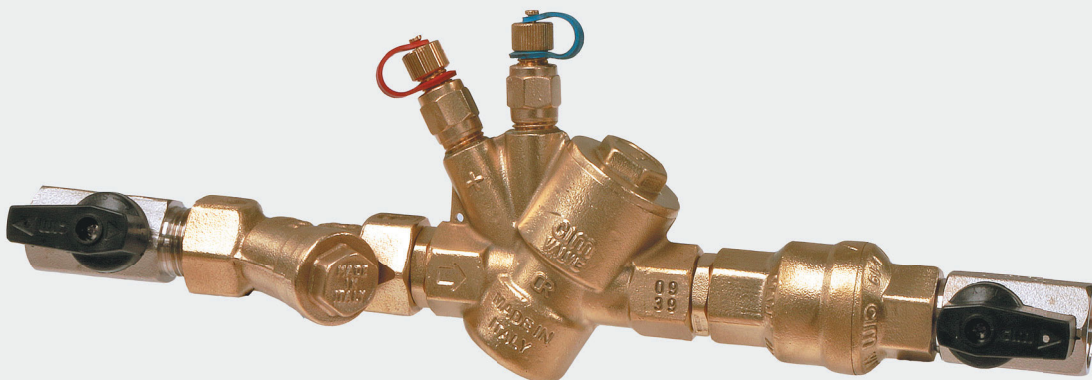

Apartment Balancing valve kit

Riser Connection Schematic

Connection Schematic without floor branch pressure control valve

Note that it is ideal to keep all dead legs as short as possible. If possible, circulate hot water through the header pipe in order to reduce the volume of cold water in the pipes before the hot water meters, as shown in the schematic below.

NOTE: If using this arrangement with individual pressure reducing valves or pressure limiting valves on each branch, then the valves **MUST** be set to within +/-10% of each other.

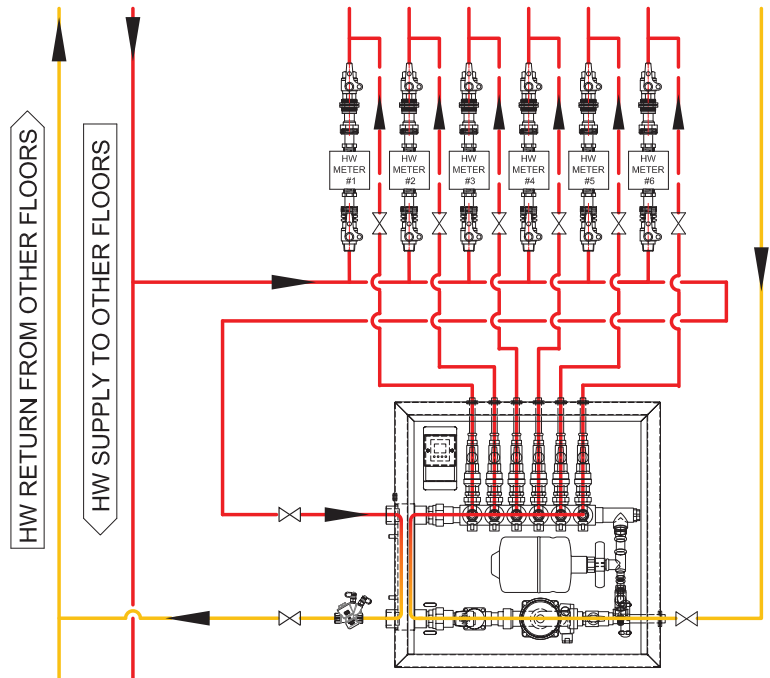

Connection Schematic with floor branch pressure control valve

If floor branch pressure control valves are installed before the header manifold, then a branch must be taken immediately before in order to allow water to circulate to the H-BOX on the primary inlet side.

NOTE: the header manifold after the PRV is a dead leg and will contain cold water. This dead leg pipe must be kept to an absolute minimum to reduce temperature fluctuations supplied to the apartments and is recommended to be no longer than 600mm in 32mm copper pipe. When insulated, this length of pipe will maintain sufficient heat by conductive heat transfer of the connecting pipes.

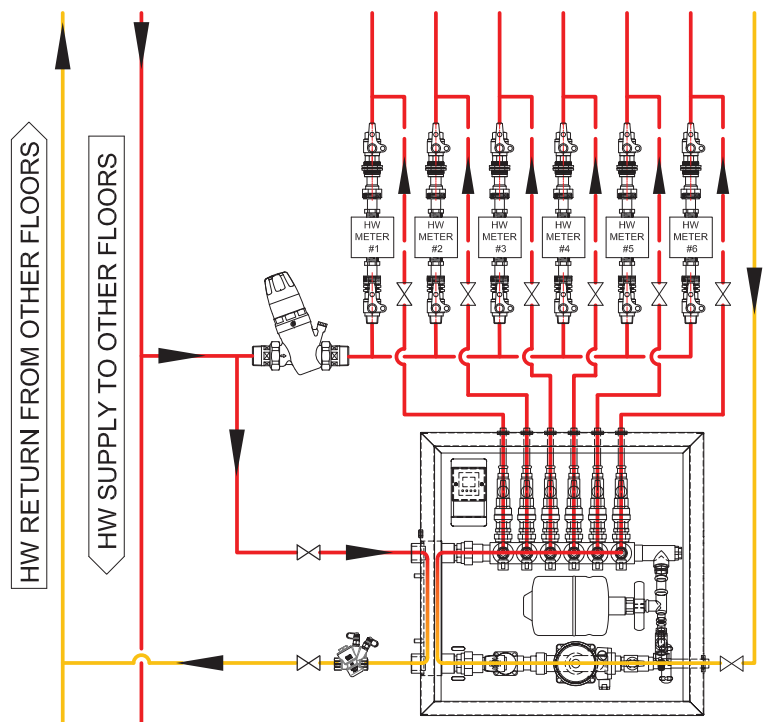

Technical specifications

Performance

Max Pressure	Primary circuit	3,400kPa
	Secondary Circuit	1,000kPa
Max operating pressure	Secondary Circuit	500kPa
Fluid temperature	5 – 70°C	
Recommended Primary circuit flow rate	0.08 l/s (HBox6)	0.11/s (HBox10)
Tempering Valve (Optional) Adjustable range	30 – 50°C	

Connections

Primary Circuit	Inlet / Outlet	25mm BSP
	Outlet Branches	15mm copper pipe
Secondary Circuit	Inlet Return	20mm copper pipe
Dry weight	20kg (Hbox6)	25kg (Hbox10)

Electrical

Electric Supply	10A GPO, 230 – 240V (ac) 50Hz	
Power consumption	158W	
Current Consumption	0.7A	
Protection Class	Pump	IP44
	Solenoid	IP65
	Timer	IP20

Materials

Pump / Solenoid / Heat Exchanger / Manifold	Stainless Steel
Ball Valves / Threaded Fittings	DZR Brass
Strainer Mesh	Stainless Steel
Pump Impeller / Check Valve Inserts	Plastic (PPO)
Seal, Gaskets and O-rings	NBR 70 / EPDM / PTFE
Pipe and Crimp Fitting	Copper
Cabinet	Stainless Steel

Dimensioned drawings

Sizes

A	600mm (Hbox6) / 800mm (Hbox10)
B	600mm
C	234mm
D	110mm
E	175mm
F	50mm
G	125mm
H	104mm
I	45mm

H-box Multi Zone Part Number Ordering

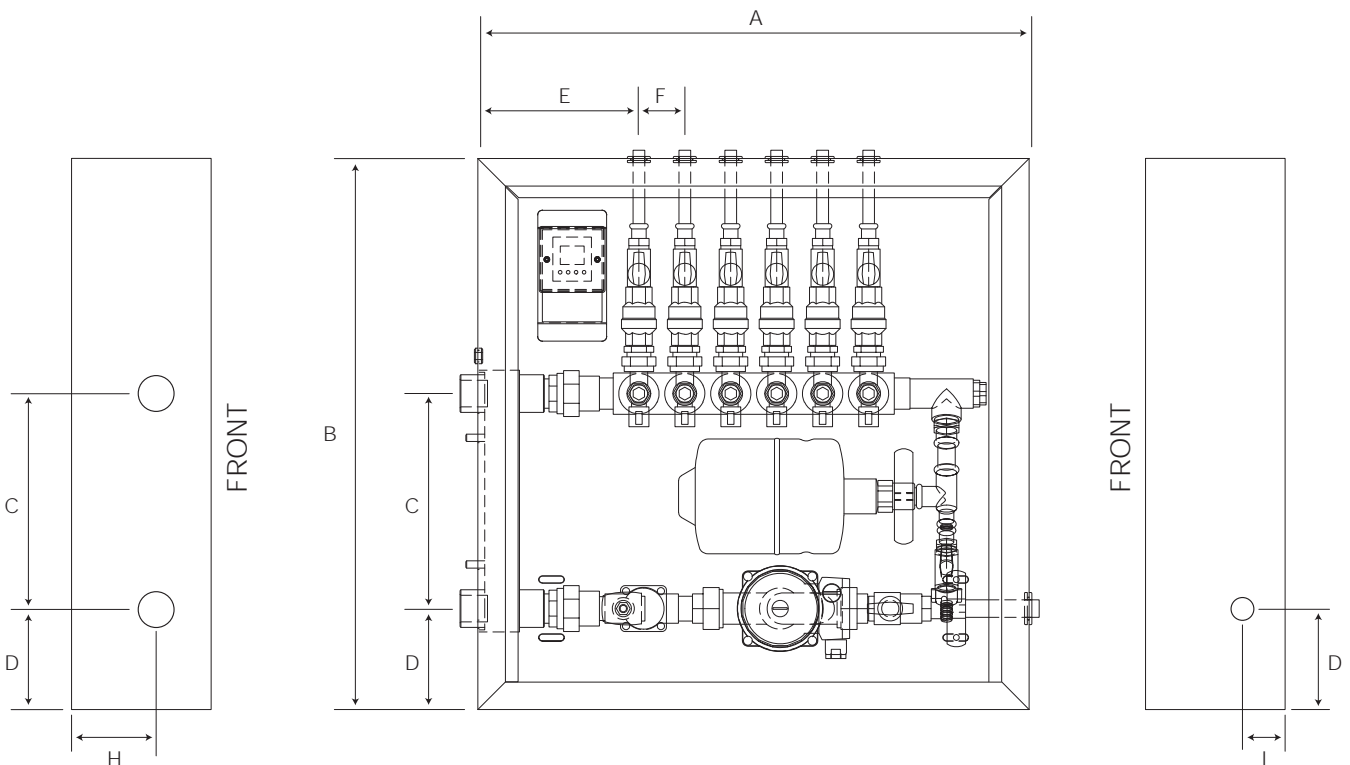
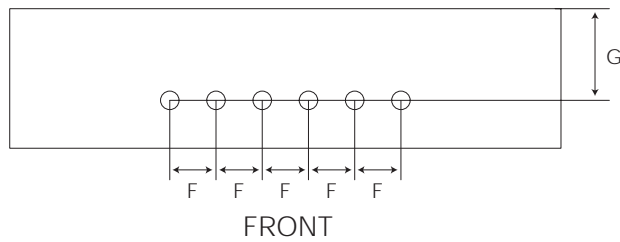
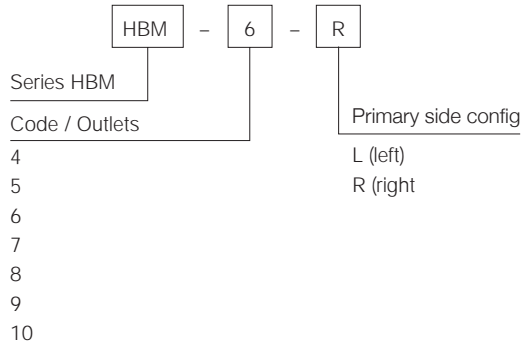

The layout can be flipped to allow left primary side connection with right side return pipe connections or vice versa. The outlet connections are always centred on top of the cabinet. Connection side to be specified at the time of order.



H-BOX SINGLE ZONE Hot Water Circulation System

A basic circulation system with a heat exchanger, dual circulation pumps, expansion tanks, and digital timer controller has been designed and pre-packaged to improve the ability to circulate hot water through a building, especially where separate zones need to be created due to pressure considerations.

The Single Zone Hot Water Circulation unit can be used in a wide range of applications including domestic and commercial buildings to separate heating zones. It is especially suited to where pressure control stations exist and need to be bypassed to continue circulating hot water.

Features

- ◆ Compact and easy to install
- ◆ Engineered for 'plug and play' installation
- ◆ Thermal expansion control with expansion tank and expansion control valve
- ◆ Automatic air vent
- ◆ Watermarked components

Controller

- ◆ Main Isolator Switch and Circuit Breaker protected Control Circuit
- ◆ Auto/Off/Manual Operation of Both Pumps, configured for duty alternation
- ◆ LED Indicator Lights for System Status indication

Options available;

- ◆ stainless steel lockable weatherproof enclosure
- ◆ floor support stand with rubber feet (recommended)



Design guide

General

- ◆ Each HW riser requires a dedicated return line as H-box requires connection to both flow and return risers.
- ◆ Install H-BOX in close proximity to the pressure control station.
- ◆ Gas meters need to be installed in a separate cupboard due to the electrical supply, as per Gas Code.

Primary Side

- ◆ Calculate the flow rate of the primary circuit based on 3°C max temperature drop.
- ◆ Allow for minimum X kPa pressure drop across H-BOX Single-Zone model (see technical data) to be used for hot water plant circulation pumps sizing.

Secondary Side

- ◆ Calculate the heat load and flow rate of the secondary circuit based on 3°C max temperature drop.
- ◆ Review the H-BOX models and select a suitably sized unit for the heat load requirements.
- ◆ Allow for minimum X kPa pressure drop across H-BOX Single-Zone model (see technical data) when reviewing the H-BOX pump curve.

Example for product selection

A 40 storey building has 3 risers. The pressure needs to be broken approximately halfway with the bottom 20 floors being zoned with a pressure control valve station, along with a single H-BOX system to serve the 3 x 65mm risers to create secondary circulation loops.

3 x 65mm risers over 20 floors = 180 metres of pipe
180 x 24W/m heat loss = 4,320 Watts

Therefore, select 5kW model "HBS-5" to serve the heat loads in the secondary circuits (bottom half of building). Add heat load requirements of both primary and secondary zones together when considering the hot water plant size. Also, note that if there are multiple pressure zones in a building, for example A, B & C with H-BOX units in Zone B and Zone C, then the H-BOX in Zone B must have sufficient capacity to allow for the heat load required in both B + C.

Technical specifications

Performance

Max Pressure	Primary circuit	3,400kPa			
	Secondary Circuit	1,000kPa			
Max operating pressure	Secondary Circuit	500kPa			
Fluid temperature	5 – 70°C (up to 80°C for 2 hours)				
H-box – Single Zone Model		S5	S12	S22	
kW rating of unit (at 3° ΔT)		5kW	12kW	22kW	
	(at 5° ΔT)	8kW	18kW	36kW	
Nominal flow rate (Primary Flow)		0.4 l/s	0.9 l/s	1.8l/s	
Nominal flow rate (Secondary Flow)		0.4 l/s	0.9 l/s	1.8l/s	
Pressure Loss at nominal flow (Primary)		2kPa	8kPa	12kPa	
Pressure Loss at nominal flow (Secondary)		6kPa	12kPa	16kPa	
Connections					
	Primary	Inlet / Outlet (BSP)	25mm	40mm	50mm
	Secondary	Inlet / Outlet (copper/BSP)	25mm	40mm	50mm
Dry weight		34kg	56kg	68kg	

Materials

H-box – Single Zone Model	S5	S12	S22
Heat Exchanger / Manifold	SS	SS	SS
Pump	SS	Brass	Brass
Valves / Threaded Fittings	Brass	Brass	Brass
Seal, Gaskets and O-rings	NBR 70 / EPDM / PTFE		
Pipe and Crimp Fitting	Copper		
Backing Plate (standard)	Galvanised steel		
Lockable Enclosure (optional)	Stainless Steel		

H-box Single Zone Part Number Ordering

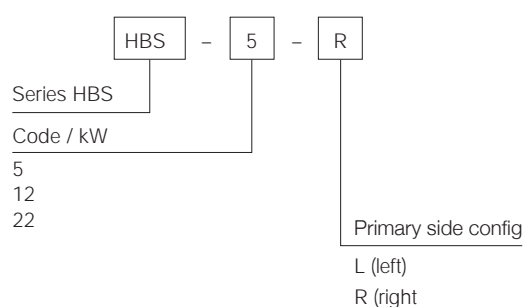

Electrical

H-box – Single Zone Model		S5	S12	S22
Max power consumption		156W	345W	345W
Current Consumption		0.7A	1.67A	1.67A
Protection Class	Pump	IP44	PX4D	IPX4D
	Controller	IP44	IP44	IP44
Required Electric Supply		10A GPO, 230V (AC) 50Hz		
Fault Output		Voltage free normally open ‘common fault’ output (rated to 24VDC, 1A).		
<i>Refer to specific Pump and Controller datasheets for further details</i>				

Pump Charts

H-box Single Zone “S5”

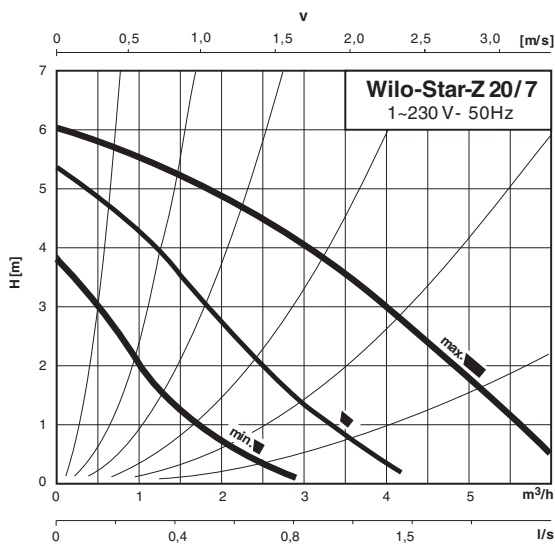

H-box Single Zone “S12” and “S22”

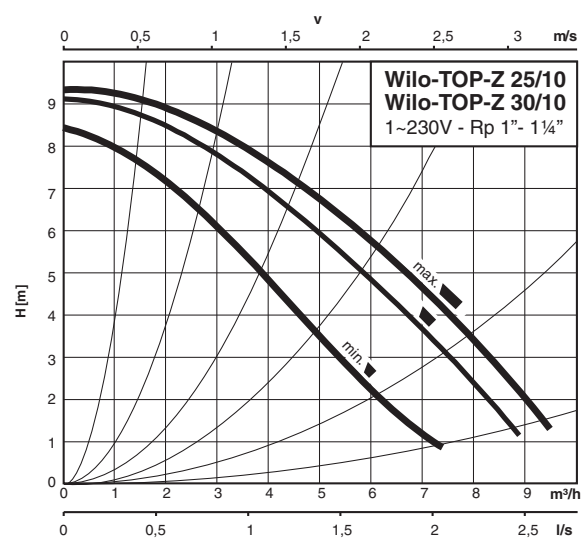

Dimensioned Diagram

	H (mm)	W (mm)	D (mm)
S5 (5kW)	900	650	180
S12 (12kW)	1,200	750	280
S22 (22kW)	1,200	750	280

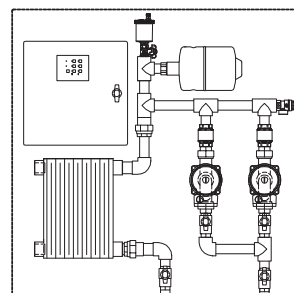

LHS

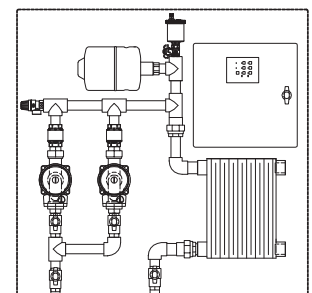

RHS

Application Diagrams

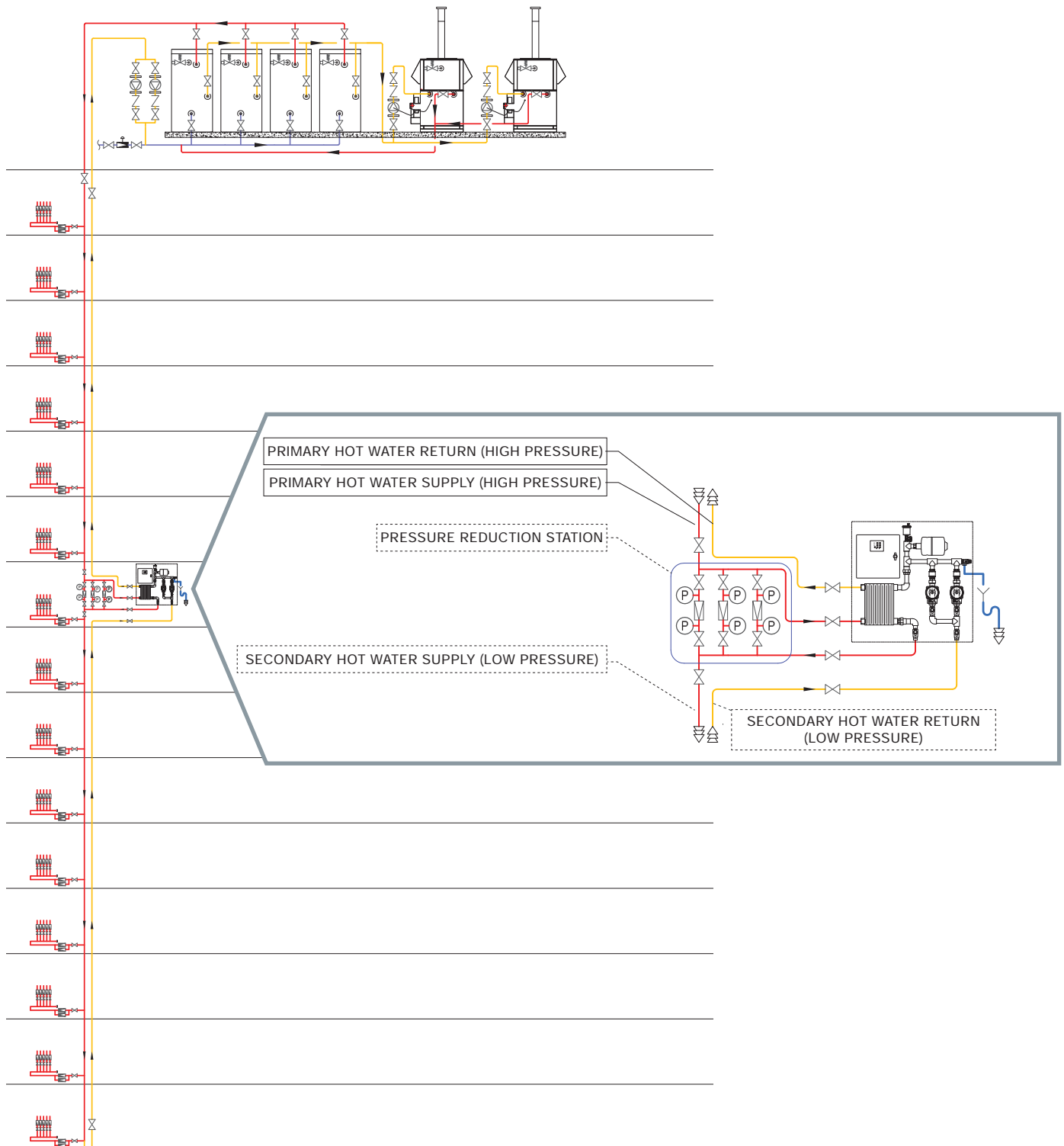

Multiple Riser System

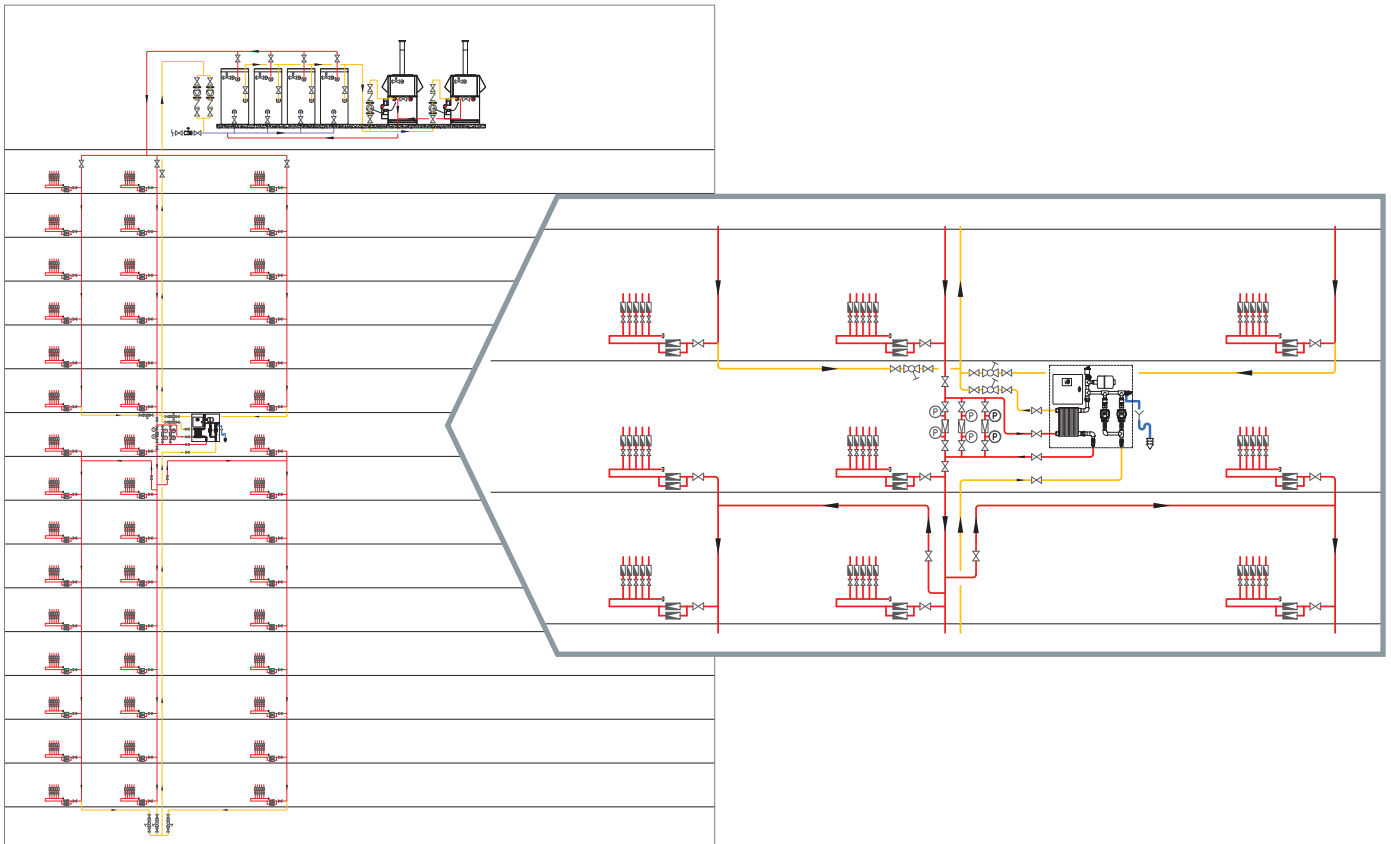

Ring Zone System

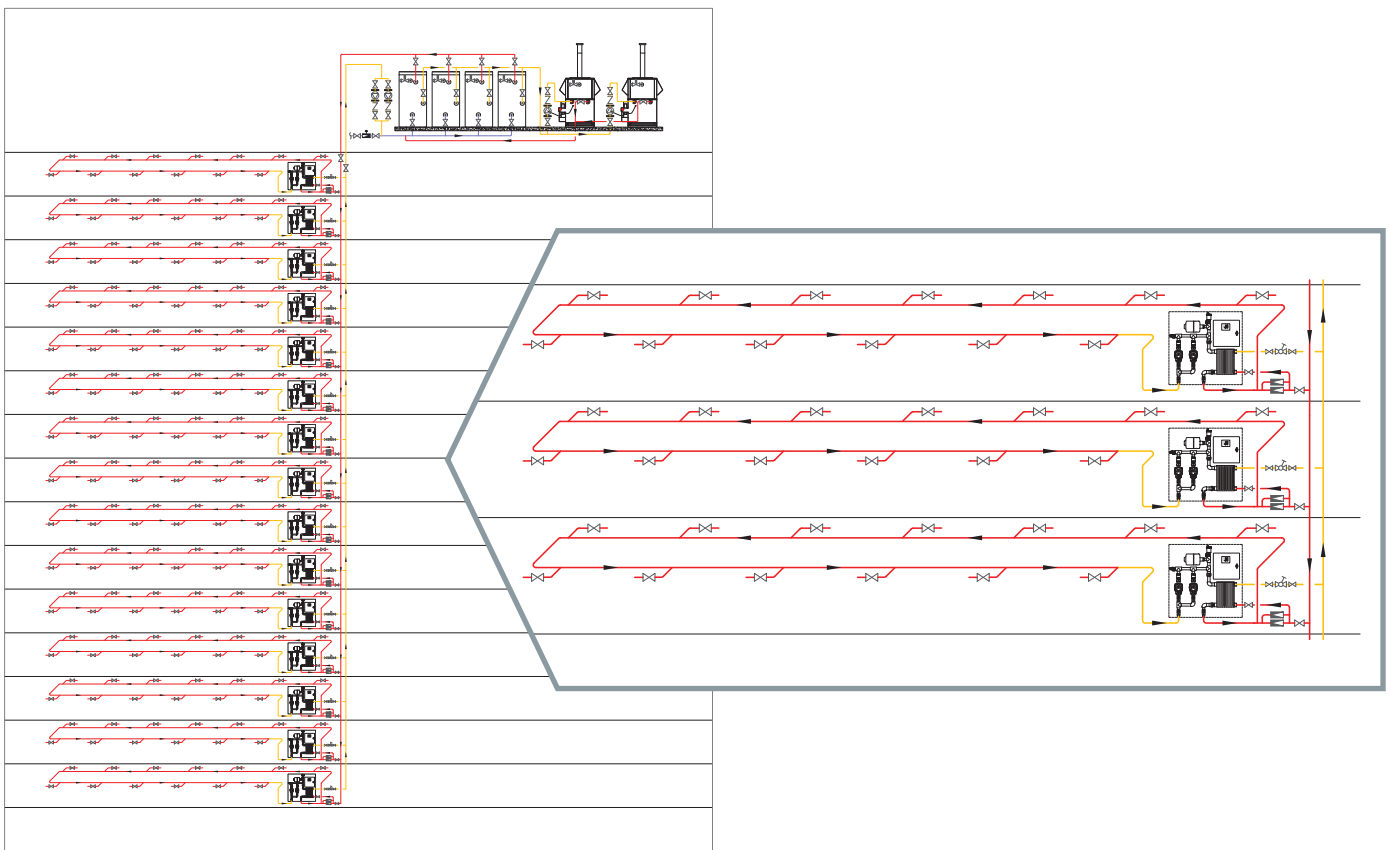



H-BOX MINI Hot Water Circulation System

The HBS-1 mini H-BOX system has been designed to facilitate hot water circulation for a larger dwelling such as a penthouse or townhouse to maintain the water temperature in pipes, thereby providing improved hot water delivery times to the fixtures.

The HBS-1 has been specifically designed to overcome limitations in circulating hot water due to constraints relating to the hot water meter or pressure control valve which would normally hinder the ability to circulate water to each fixture.

The HBS-1 mini H-BOX system is a pre-assembled unit comprising of a heat exchanger, circulation pump, expansion tank and secondary side balancing valve.

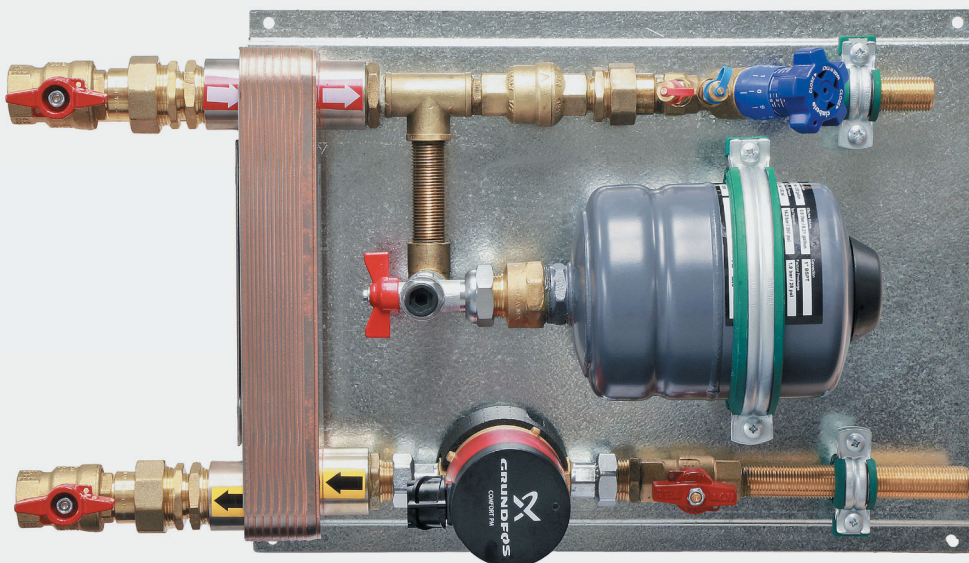

Design guide

General

- ◆ The HBS-1 normally requires a connection to both flow and return risers.
- ◆ Install HBS-1 in close proximity to the hot water meters.
- ◆ Gas meters need to be installed in a separate cupboard due to the electrical supply, as per Gas Code.
- ◆ Tempering valve(s) must be located within the apartment on a branch off the hot water circulating loop. It is suggested that each bathroom is installed with a dedicated tempering valve to maximise the benefit of the HW delivery time offered by the H-BOX solution.
- ◆ Supply and return lines to/from apartments to be lagged in accordance with AS3500.4 to minimise heat-loss. Insulation should be installed on all circulating pipes to a rating of at least R0.6, with a recommended value of R1.0.

Primary Side

- ◆ Calculate the flow rate of the primary circuit based on 5°C max temperature drop, including the heat loads required of the secondary circuits in the flow rate calculation.
- ◆ Allow the following pressure losses for hot water plant circulation pumps sizing;
 - 15kPa pressure drop across HBS-1 model if used with a balancing valve
 - 2kPa if no balancing valve is used, up to the maximum flow rate of 0.4l/s circulating flow.

Secondary Side

- ◆ Calculate the heat loss of the secondary circuit and ensure it is < 1.5kW to confirm the HBS-1 is sufficiently sized (based on the secondary circuit requiring max 5°C ΔT)
- ◆ Calculate the flow rate of the secondary circuit based on 3-5°C max temperature drop. Flow rate to be used for setting of balancing valve during commissioning.

Example

A 6 storey building has two risers, both with a 40mm flow riser + a 25mm return riser, and a HW plant in the basement. Hot water meters are located in the riser cupboards.

Two penthouse suites are located on the top floor at the end of each riser and require circulation through the apartment to reduce hot water delivery times, each to be served by its own HBS-1 unit.

Primary Side

2 x 40mm flow risers over 6 floors = ~ 40 metres of pipe

40 x 15W/m heat loss = 600 Watts

2 x 25mm return over 6 floors = ~ 40 metres

40 x 11W/m heat loss = 440 Watts

Penthouse suites will circulate 40 metres each in 20mm pipe in the secondary zone

2 x 40 x 9W/m heat loss = 720 Watts

Total = 600 + 440 + 720 = 1,760Watts

Primary side flow rate @ 5°C ΔT = 0.084 l/s

Secondary side

Each penthouse suite has a 40m loop in 20mm pipe and is served by its own H-BOX mini system.

40 x 9W/m = 360 Watts

360 Watts < 1,500 Watts max heat load suggested of the HBS-1, therefore the system is suitable.

360 Watts @ 3°C ΔT = 0.03 l/s circulating flow rate in the secondary side - to be set at the balancing valve and pump during commissioning.

Technical specifications

Performance

Max Pressure	Primary circuit	3,400kPa
	Secondary Circuit	1,000kPa
Max operating pressure	Secondary Circuit	500kPa
Fluid temperature	5 – 70°C (up to 80°C for 2 hours)	
S1		
kW rating of unit	(at 3° ΔT)	1kW
	(at 5° ΔT)	1.5kW
Nominal flow rate (Primary Flow)		0.4 l/s
Nominal flow rate (Secondary Flow)		0.08 l/s
Pressure Loss at nominal flow (Primary)		2kPa
Pressure Loss at nominal flow (Secondary)		5kPa
Connections		
Primary	Inlet / Outlet (BSP)	20mm (25mm upon request)
Secondary	Inlet / Outlet (BSP)	15mm
Dry weight	11kg	

Materials

S1		
Heat Exchanger	Stainless Steel / Copper	
Pump	Brass	
Valves / Threaded Fittings	Brass	
Seal, Gaskets and O-rings	NBR 70 / EPDM / PTFE	
Backing Plate (standard)	Galvanised steel	

Electrical

S1		
Max power consumption	< 20W	
Required Electric Supply	10A GPO, 230V (AC) 50Hz	

Pump Charts

H-box Mini "S1"

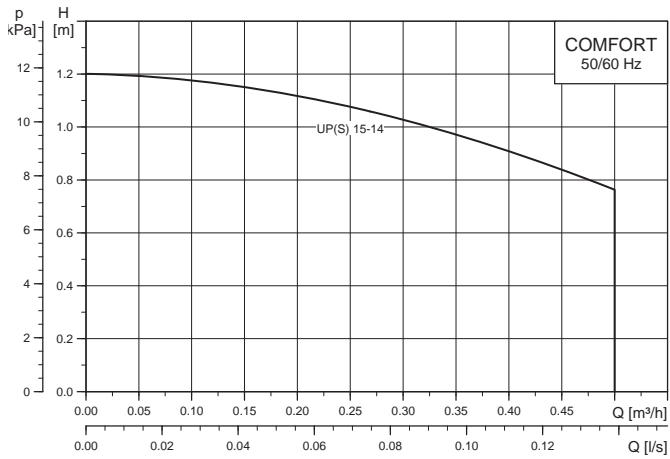

Refer to specific Pump and Controller datasheets for further details

Dimensioned Diagram

HBS-1

Length 550mm

Width 360mm

Depth 170mm

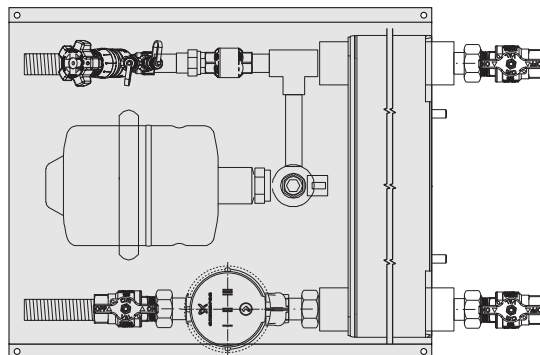
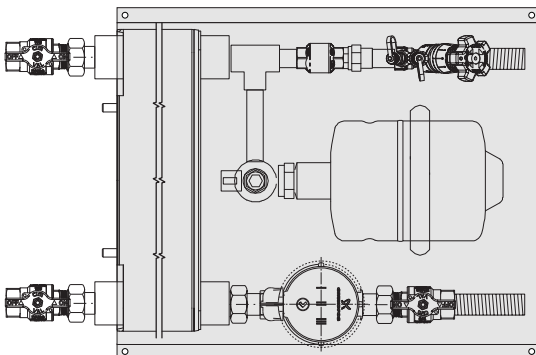

Application Diagrams

Connection schematic with primary side connected to flow and return riser

Note that a balancing valve is required to be installed on the primary side return line. The primary side balancing valve is not supplied with the HBS-1 as standard. In addition, consideration must be made to ensure that other circuits within the system also have balancing valves to ensure the system can be balanced accordingly.

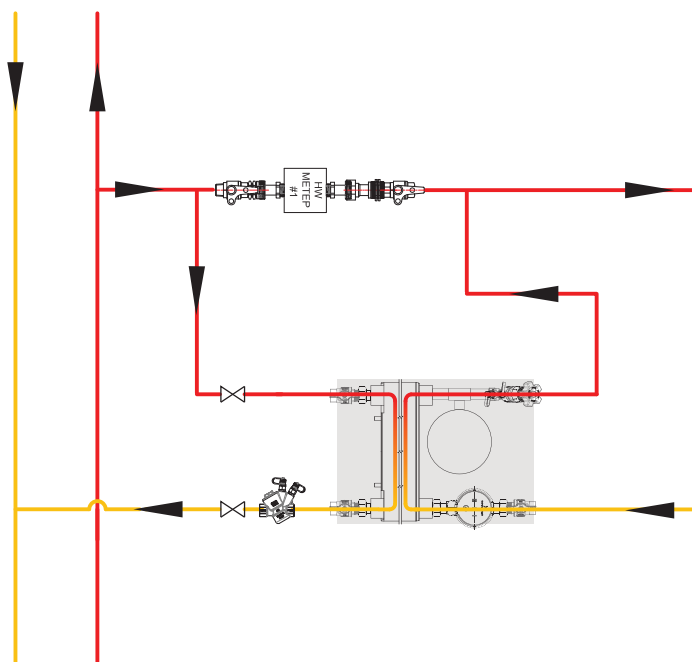

Connection schematic with primary side connected to return riser only

Diverting 100% of the return flow rate through the heat exchanger can be considered, noting that the connection size is 20mm (or 25mm upon request). No balancing valve is required with this arrangement.

Multiple HBS-1 in series will affect temperature and pressure loss through return circuit. Please confirm with All Valve Industries if this setup is suitable if being considered for a project.

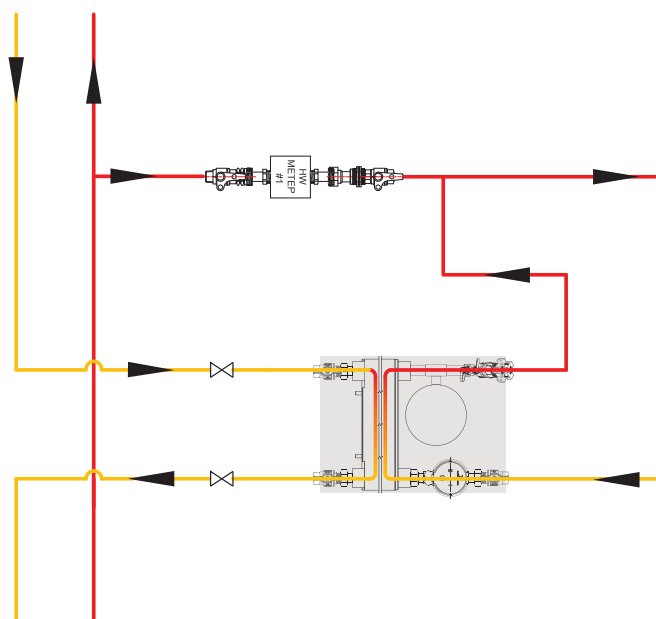



www.allvalve.com.au

Unit 2, 18 Sir Joseph Banks Drive
Kurnell NSW 2231
Sydney Australia

ph: +61 2 8543 9811
fax: +61 2 8543 9822
email: sales@allvalve.com.au

