

METER BOX & BRACKET ASSEMBLIES

FOR ICON WATER (ACT) METER INSTALLATIONS

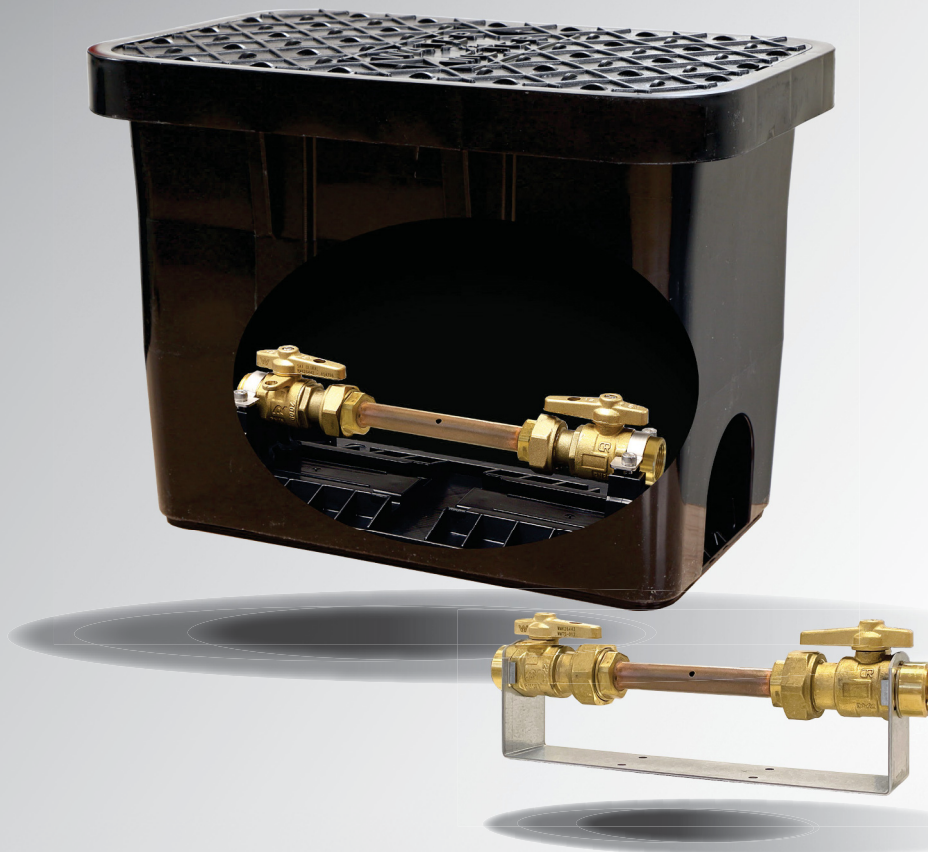

PRE-ASSEMBLED KITS FOR FAST, SIMPLE INSTALLATION OF WATER METERS

FUNCTION AND FEATURES

■ Minimal Joints

Integrated meter connection swivel nut ball valves means no unnecessary leak points.

■ Innovative Design

Simple, robust and durable delivers perfect component alignment for meter installations.

■ Quick Installation

Prefabricated kits, along with our quick fit box design, vastly cuts down on installation time.

■ Approved Product

Approved by Icon Water for the new DN20 water meter installations.

PRODUCT DETAILS

BALL VALVES

Airaga brand ball valves are Italian quality and are versatile and compact; featuring an inbuilt swivel nut and tail which minimises the chances of leaks from common points of assembly and the need for thread tape and adhesives. The swivel nut face and gasket, which connects to the meter, is virtually a flat face and has been designed in such a way that allows for a much easier removal of the water meter.

METER BOX

The meter box is manufactured in New Zealand by Draper and features a base with sliding valve brackets, as well as locators and retaining clips which allows the box to quickly and easily push fit together during installation.

WALL BRACKETS

The sub meter brackets have been specifically designed for quick and easy installations and retains the valves so they do not rotate during installation.

The in-ground meter box and wall sub-meter brackets are approved by Icon Water for use with their new metering standards.

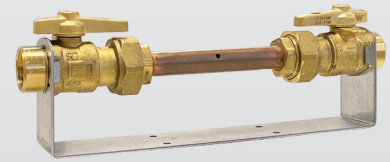

CODE	DESCRIPTION
AVMB-2BSPN/BP	Meter box with 2x female BSP ball valves and Icon Water meter spacer
SMLIMSS-BP	Sub meter bracket kit with 2x female BSP ball valves and Icon Water meter spacer

DIAGRAM

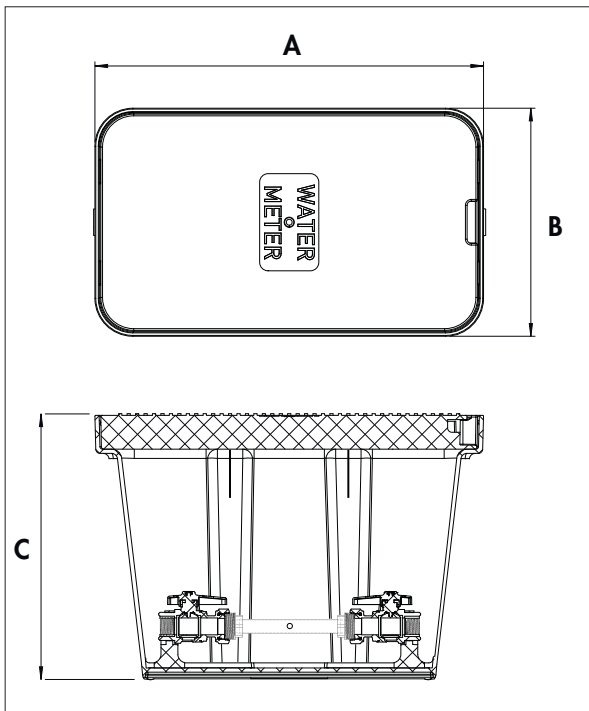

Meter Spacer
A water meter spacer piece is supplied with both the meter box and the bracket kit. This meter spacer must be returned to Icon Water when applying for your new water meter.

For more information, please visit the Icon Water website at www.iconwater.com.au or contact 6248 3111.

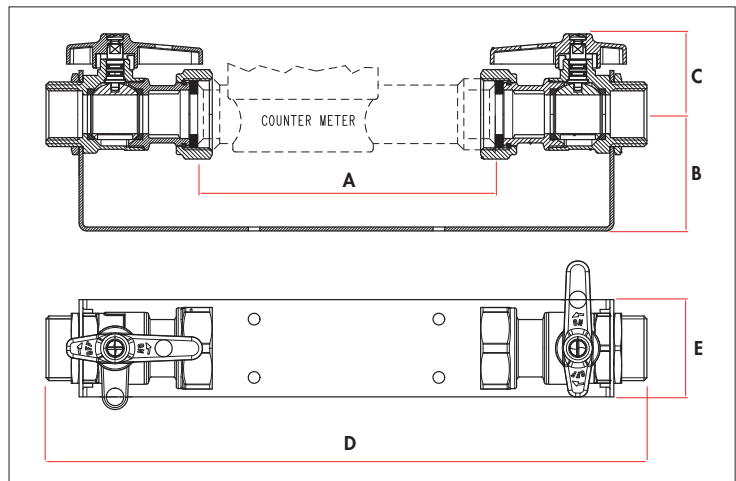
CODE	BRACKET	METER BOX
A	153mm	445mm
B	60mm	290mm
C	41.5mm	320mm
D	309mm	
E	50mm	



All Valve
INDUSTRIES

240123-00