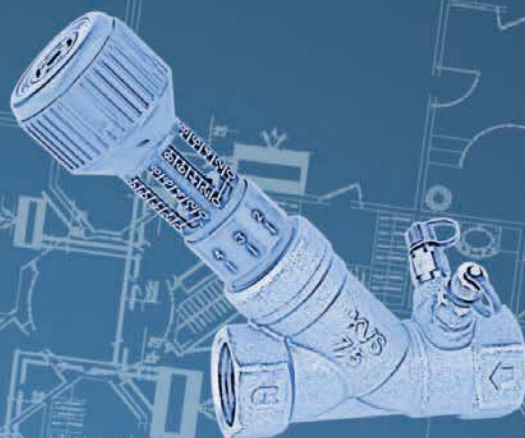
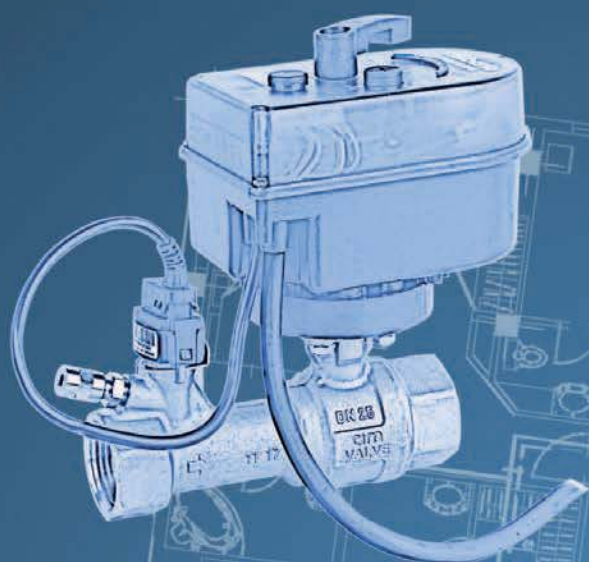


valve  
**cimberio**<sup>®</sup>

technological solutions



**Balancing Valves Handbook**





# Balancing Valves Handbook

## Index

<b>1</b>	<b>INTRODUCTION</b>	<b>4</b>
<b>2</b>	<b>THE IMPORTANCE OF FLOW REGULATION</b>	<b>4</b>
2.1	Principles for balancing hydronic systems	4
2.1.1	Heat transfer at reduced flow rate	4
2.1.2	Heat transfer at excessive flow	6
2.1.3	Chilled water terminal	6
<b>3</b>	<b>REGULATING VALVES AND FLOW MEASUREMENT DEVICES</b>	<b>7</b>
3.1	Manual balancing valves	8
3.1.1	Examples: Comparison between a balanced and an unbalanced system	9
3.1.2	Double regulating valves	13
3.1.3	Regulating 2-way control valve	13
3.1.4	Fixed orifice flow measurement devices	14
3.1.5	Fixed orifice double regulating valves	15
3.1.6	Variable orifice double regulating valves	16
3.2	Fixed orifice versus variable orifice	17
3.2.1	Flow measurement accuracy	17
3.2.2	Why flow measurement accuracy is important	17
3.2.3	Conclusion	18
3.3	Automatic balancing valves	18
3.3.1	Constant flow regulator	18
3.3.2	Differential pressure control valves	20
3.3.3	Pressure independent control valves	23
<b>4</b>	<b>DESIGN CONSIDERATIONS</b>	<b>25</b>
4.1	Self-balancing arrangements	25
4.2	Velocities	26
4.3	Pump selection	26
4.4	Variable speed pumps	26
4.5	System cleanliness	26
4.6	Venting and draining	26
4.7	Access	27
<b>5</b>	<b>GUIDELINES FOR VALVE SELECTION</b>	<b>27</b>
5.1	Terminology	27
5.2	Selection criteria	28
5.3	Selection procedure	28
5.4	Software for selection	29
<b>6</b>	<b>MEASURING FLOW RATE</b>	<b>30</b>
6.1	Fluorocarbon/mercury manometer	30
6.2	Digital manometer	31
<b>7</b>	<b>FLOW REGULATION PROCEDURE</b>	<b>32</b>
7.1	Proportional balancing	32
7.2	Index circuit	32
7.3	Proportional balancing procedure	33
7.4	Reporting	33
<b>8</b>	<b>INDEX OF FIGURES</b>	<b>34</b>
<b>9</b>	<b>INDEX OF TABLES</b>	<b>35</b>
<b>10</b>	<b>BIBLIOGRAPHY</b>	<b>35</b>



# Balancing Valves Handbook

## Introduction

### 1. Introduction

This guide explains how to select, install and operate Cimberio's range of regulating valves and flow measurement devices. The products discussed are primarily intended for use in heating and air conditioning systems.

The guide is intended for engineers involved in the design of systems, and the selection of regulating valves and flow measurement devices. It is also aimed at installing contractors who may need to interpret the engineer's instructions and install or operate these products.

### 2. The importance of flow regulation

The possible consequences of inaccurate flow regulation are as follows:

- **Failure to achieve design temperatures:** Terminals receiving too little flow may not deliver their intended amounts of heating or cooling. This will mean that the areas they serve may fail to reach design temperatures under peak load conditions.
- **Wasted energy:** A system with poor flow balancing will heat up or cool down unevenly i.e. the areas starved of flow will take much longer to reach their design temperature than areas which have excess flow rate. This means that the system as a whole will have to operate for longer periods in order to ensure that design temperatures are achieved during occupancy periods.
- **Noise, erosion or air and dirt blockages:** Unbalanced systems will have regions of excess flow and regions of reduced flow. Excessive flow velocities may give rise to noise generation and erosion of system components. Reduced flow velocities may encourage the settlement of dirt particles or air bubbles.
- **Poor control valve response:** Modulating control valves may be unable to control properly if the circuits they control start off with too much or too little flow. In a circuit receiving too much flow, the first part of the control valve's travel is wasted returning the flow rate back to its design value. In a circuit receiving too little flow, the action of the control valve may cause a dramatic drop in heat transfer effectively making the controller act as on/off.

The guide also establishes the case for Cimberio's high accuracy fixed orifice regulating valves.

This type of valve has general acceptance in many parts of the world due to the benefits of flow measurement accuracy and performance. The reasons for its increasing popularity over variable orifice valves are summarised in **Section 3.2**.

The advantages of automatic balancing valves are analysed in **Section 3.3**.

- **Difficulty adjusting system performance:** If there is no clear record of flow rates and valve settings, it becomes very difficult, during subsequent operation of the system, to correct performance problems or fine tune the system to achieve optimum performance.

#### 2.1 Principles for balancing hydronic systems

##### 2.1.1 Heat transfer at reduced flow rate

The room heat emitters undergo a reduction in output capacity if their input flow rate is reduced.

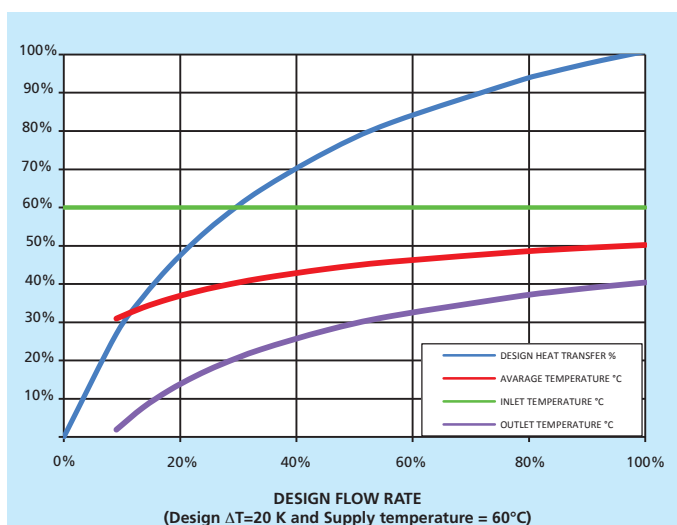


Figure 1  
Effects of flow variation



# Balancing Valves Handbook

## The importance of flow regulation

Let's consider a classical emitter, fed at a constant temperature of 60°C and analyse the influence that flow variations have on the heat output capacity.

- At the design operating conditions you have the nominal flow rate with the temperature rise adapted during the sizing phase;
- Reducing the flow rate also reduces the output capacity (the reduction also depends on the delivery temperature); in this case, if the flow rate is reduced to 40%, the capacity will be reduced to 70% of the nominal capacity;
- The temperature rise increases with the reduction in the flow rate;
- If a control valve reduces the output capacity to 50% of the nominal capacity, the flow rate should be reduced to about 22%.

In transferring the heat from the heat-transfer fluid to the air, the parameter that effects efficacy the most is therefore the difference between the mean temperature of the water and that of the air.

To remedy an undersized emitter one very often raises the system's supply temperature. The graph below shows how the necessary capacity can be obtained at reduced flow rates by simply increasing the supply temperature. For example, considering an emitter designed with a generic flow rate  $Q$  that develops a capacity of  $X$  Watts at a supply temperature of 60°C.

If for whatever reason the actual flow rate is reduced to 60%, a supply temperature of only 65°C needs to be maintained to have 95% of the required capacity. The problem seems to be resolved, but only partly.

There will surely be other emitters that will instead have a flow rate that is higher or equal to that needed. In this case the output capacity will be higher than what is necessary. Considering an emitter that receives the designed flow rate, an increase of the supply temperature to 65°C corresponds to an increase in capacity of approximately 16%.

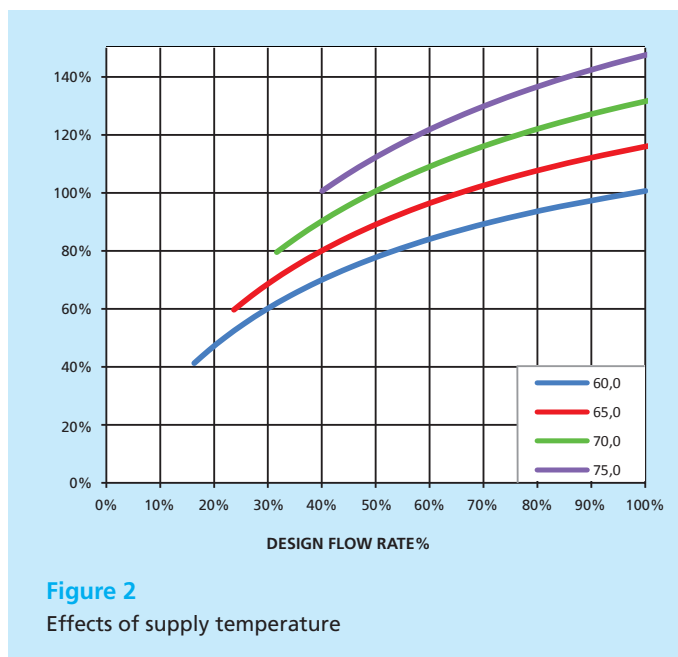


Figure 2  
Effects of supply temperature

This operation has the following negative effects:

- The system must supply the emitters for long periods to be able to keep the temperature constant in the rooms;
- An increase in the heat load makes the emitter unable to maintain the design temperature;

Flow control valves (2-way control valves, Thermostatic valves) with a standard range (for example 30:1) could have an unstable system control (on/off) due to a reduction in the flow rate and a resulting reduction in authority;

The last aspect to consider is the temperature rise, designing functional systems with high flow rates and low temperature rises (5-10 K), any imbalance (reduction in the flow rate) is fairly well tolerated even if larger piping, more powerful pumps and thus more energy is needed. While the systems that work with low flow rates and high temperature rises are more conditioned by a system imbalance. They also have the advantage of reducing costs since they require smaller piping, less powerful pumps and thus less energy.

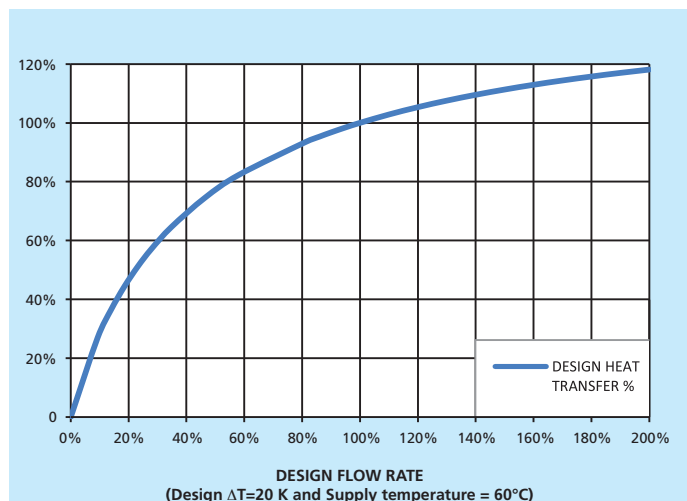


# Balancing Valves Handbook

## The importance of flow regulation

### 2.1.2 Heat transfer at excessive flow

By over supplying the emitter we get a fairly limited increase in the output capacity: a 200% increase in the flow rate is equal to an 18% increase in output capacity with 8 times the power absorption for the pump (cubic relationship between flow rate and capacity).

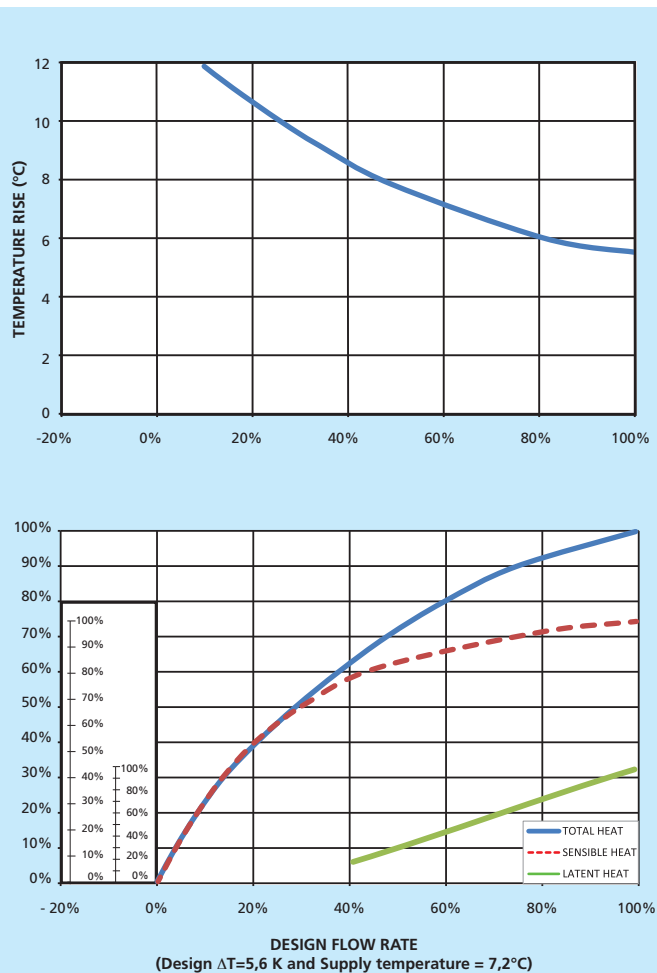


**Figure 3**  
Effects of extra flows

### 2.1.3 Chilled water terminal

The figure below shows a typical application in cooling systems: fan-coil with inlet temperature of 7.2°C,  $\Delta T$  of 5.6 K and incoming air at 26.7°C and outgoing air at 19.4 °C.

As for heating, the emitter curve is not linear and the considerations made previously generally apply.



**Figure 4**  
Effects of flow variation in cooling systems



# Balancing Valves Handbook

## Regulating valves and flow measurement devices

### 3. Regulating valves and flow measurement devices

The valves and flow measurement devices most commonly used in building services pipework systems, together with some typical applications, are described in this section. A summary of the different valve and flow measurement device types is provided in **Table 1**.

**Table 1**  
Common valve types and their functions

DEVICE		FUNCTION		
STANDARD TERMINOLOGY	DESCRIPTION	FLOW MEASUREMENT	REGULATION	ISOLATION
Isolating valve	Typically a gate or full bore ball valve with low resistance and little authority over flow. Regulating valve.	NO	NO	YES
Regulating valve	Typically a globe valve with some resistance and good authority over flow but which cannot be locked in any set position. Double regulating valve.	NO	NO	YES
Double regulating valve	A valve that has regulating ability but which can be locked in its set position, and with a valve setting indicator to enable the setting to be recorded. Fixed orifice device.	NO	YES	YES
Fixed orifice device	An orifice device that can be used for flow measurement by measuring its pressure drop and relating this to flow rate. Fixed orifice double regulating valve.	YES	NO	NO
Fixed orifice double regulating valve	A fixed orifice fitting either integral to or close coupled to a double regulating valve.	YES	YES	YES

DEVICE		FUNCTION		
STANDARD TERMINOLOGY	DESCRIPTION	FLOW MEASUREMENT	REGULATION	ISOLATION
Variable orifice double regulating valve	A double regulating valve that uses the pressure drop across its plug as the means of determining flow rate.	YES	YES	YES
Constant flow regulator (CFR)	Self-acting cartridge valve	YES	NO	YES
Differential pressure control valve (DPCV)	Self-acting valve with a flexible diaphragm whose movement is governed by an adjustable spring.	NO	YES	NO
Electronic differential pressure control valve (EDPCV)	Self-acting valve whose movement is governed by an electronic controller with a differential pressure sensor.	NO	YES	YES
Pressure independent control valve (PICV)	2-way control valve that incorporates a regulating function and DPCV.	YES	YES	YES

<sup>1</sup> Feature depends on the valve model



# Balancing Valves Handbook

## Regulating valves and flow measurement devices

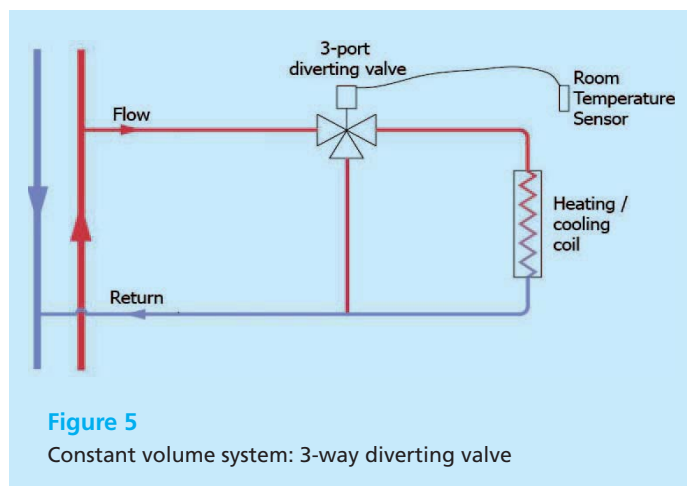
### 3.1 Manual balancing valves

Manual balancing valves are inserted to create a pressure drop so that every branch of the system is circulating at the design flow rates.

They are typically installed where there are area branches, for example, as seen in **Figure 5** in a constant flow system with output capacity control system by means of a 3-way diverting valve. The functioning can be schematically represented as follows: if the controller requests energy, the diverting valve opens to feed the supply terminal branches with heat-transfer fluid; but if the supply doesn't need to be interrupted because the desired conditions have been reached in the climate controlled area, the valve deviates the flow towards a by-pass.

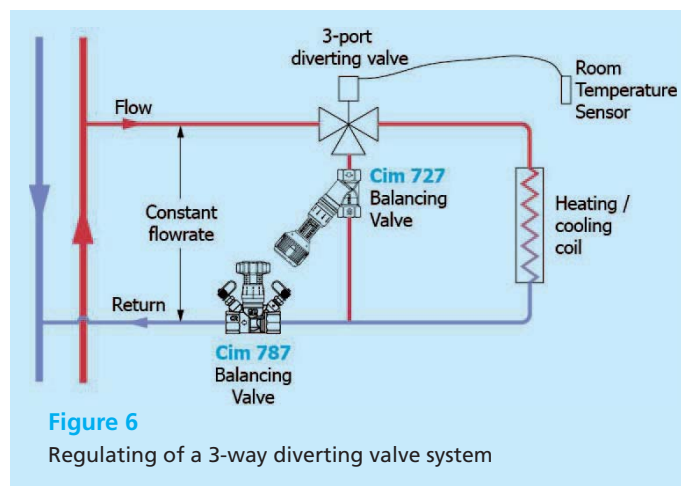
This condition will clearly create a hydraulic short-circuit, since the opposing resistance from the by-pass is definitely less than that of the connected terminal branches, and consequently the other branches that are still open will receive a reduced flow.

The solution is to create a hydraulic resistance in the by-pass so that it equals that of the emitters. This is done by installing a regulating valve and properly calibrating the system.



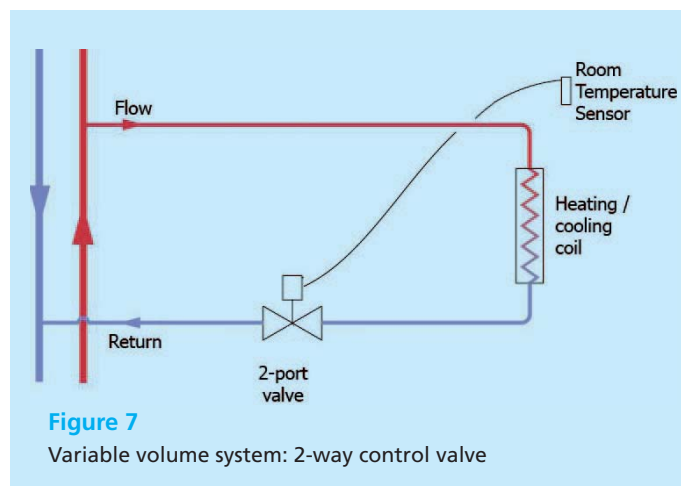
For medium-large systems, a regulating valve should also be inserted to prevent hydraulic imbalance problems caused by the network's linear length: the terminal branches "near" the circulator tend to have excessive flows, while the "far" terminal branches tend to have insufficient flows.

The installation diagram can be seen in **Figure 6**:



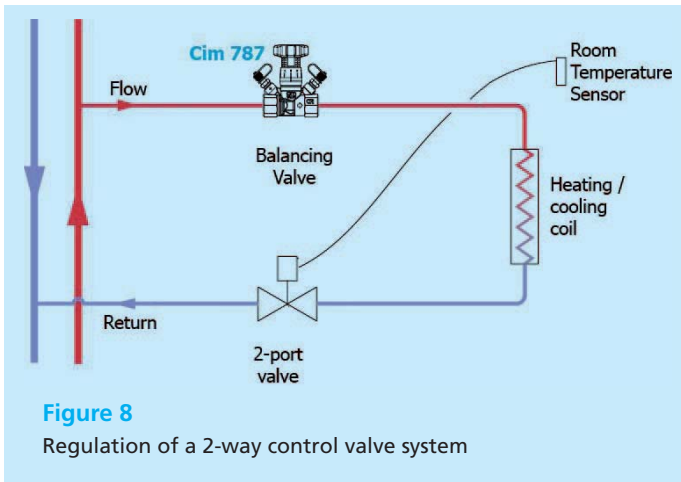
The same considerations can be made if a mixing valve is installed in place of the diverting valve.

The diagram seen in **Figure 7** is the typical check made in variable volume systems: the heat flow is regulated by a 2-way valve that can be either ON/OFF or modulating - or rather with a proportional type thermoelectric actuator.



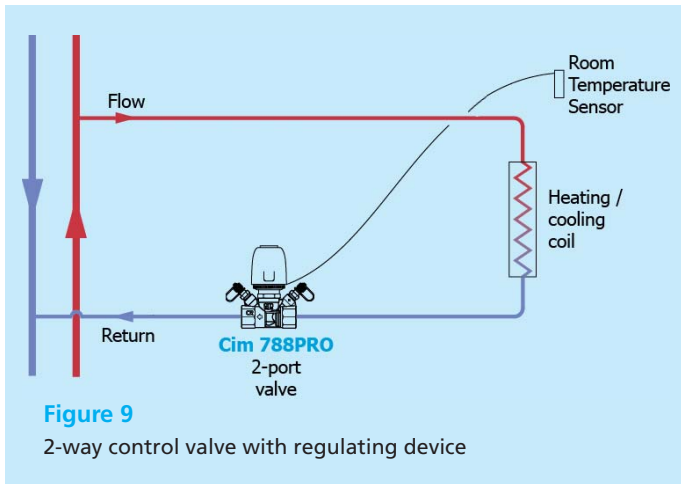
Once again, a regulating valve needs to be installed due to the problems of the system's linear length: as explained previously, the branches near the circulator are always favoured more (**Figure 8**).





**Figure 8**  
Regulation of a 2-way control valve system

Cimberio has 2-way valves with built-in regulating device (Figure 9).



**Figure 9**  
2-way control valve with regulating device

Another important aspect to consider is if one branch closes because it has reached the desired temperature, then the branches that are still open become imbalanced because it has an influence on the hydraulic resistance of the entire network. This problem can be resolved using variable speed pumps: an appropriate controller with inverter action varies the rotation speed and thus the pump's head allowing the differential pressure to be controlled at its ends. It should nevertheless be considered that, in large and medium-large systems, variable speed pumps are not enough to keep the differential pressures within acceptable limits, which can increase in the area branches and in correspondence with the valves of the heating units. This aspect will be covered in more detail with the differential pressure control valves.

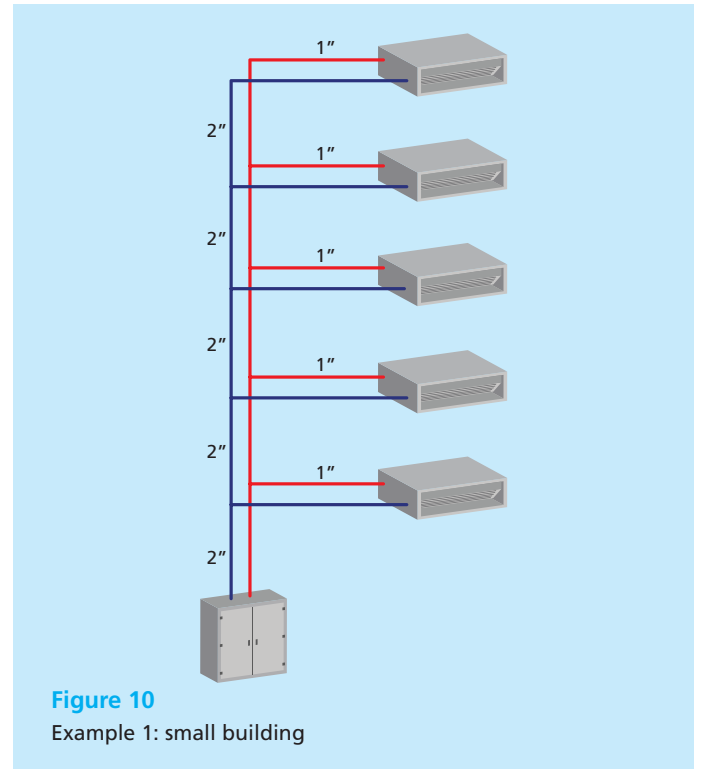
### 3.1.1 Examples: comparison between a balanced and an unbalanced system

Consider a simple system extending in height over 5 floors above ground, which feeds fan-coils with 25 kW of heating capacity each and a design  $\Delta T$  of 15K.

The circulating flow rate in each branch can be calculated using the following relationship:

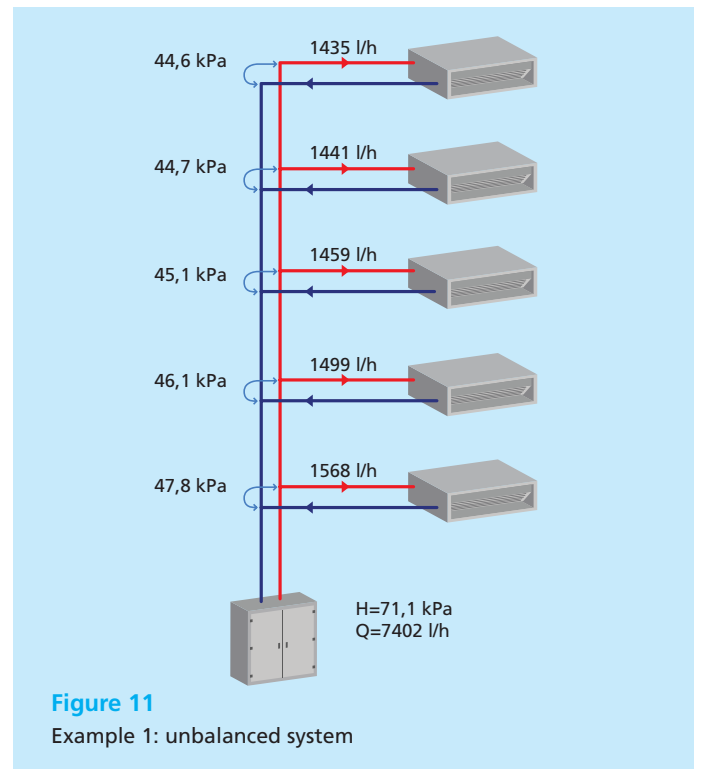
$$Q = \frac{P}{c \cdot \Delta T} = 1435 \text{ l/h} = 0.3986 \text{ l/s}$$

The steel pipes are produced according to EN 10240 standard and have a diameter of 2" (DN50) for the riser tubes and 1" (DN25) for the branches. The linear length of the network is shown in Figure 10, the distance between floors is 3 m and the branches are 5 m:



**Figure 10**  
Example 1: small building

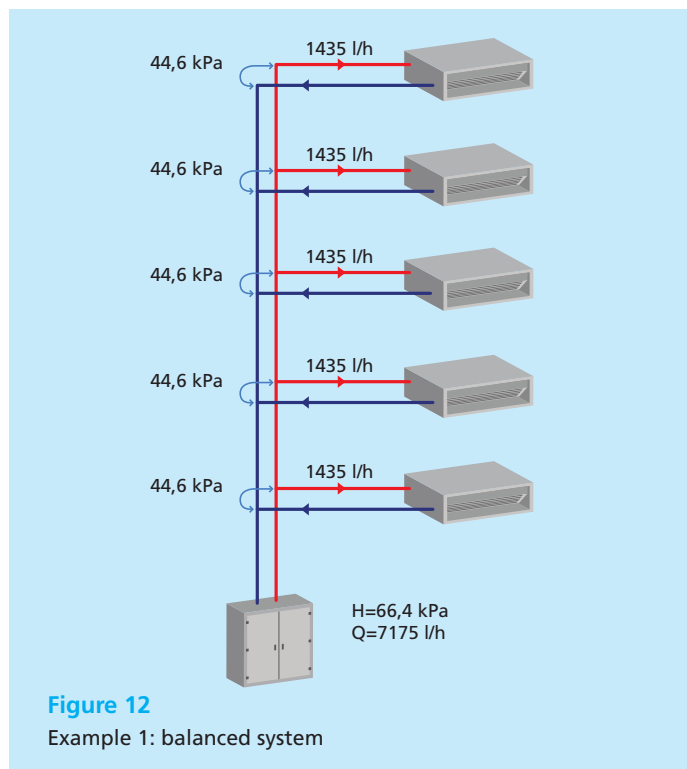
Let's now consider a system without balancing (Figure 11) where there are only 2-way valves to control the fan-coils, resolving the network and obtaining the following results:



**Figure 11**  
Example 1: unbalanced system

The first floor receives a flow excess of 9.2% (+2.8% heat capacity) and the pump head is 71.1 kPa.

Now let's look at the same network, but by adjusting the balancing valves (**Figure 12**):

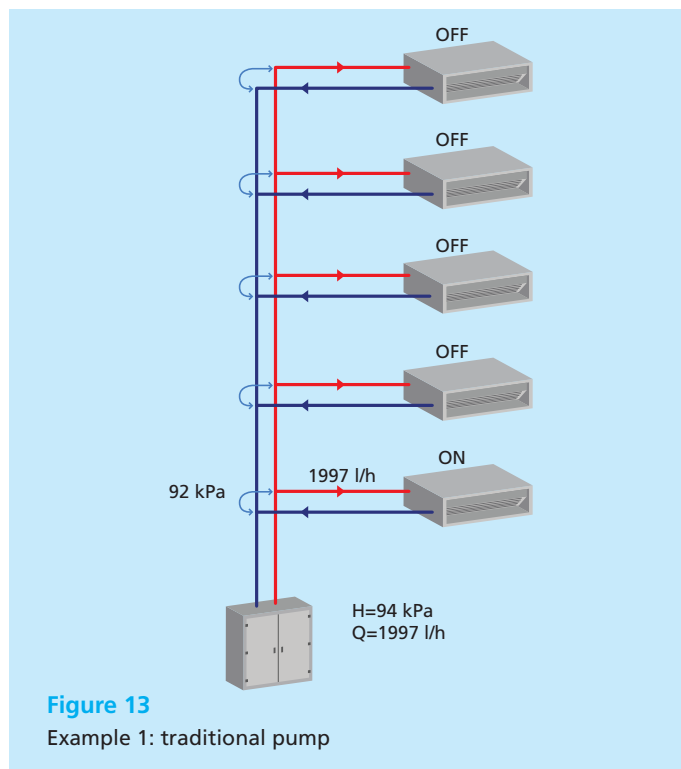


All the branches receive the design flow but the head is reduced by 6.6% and the flow rate by 3.7%. It follows that the power of the pump is reduced by 10.7%.

By regulating the system, energy waste for heating/cooling can be slightly reduced: with balancing each terminal gets the right amount of energy, avoiding oversupplying the hydraulically favoured devices in order to supply the disadvantaged devices.

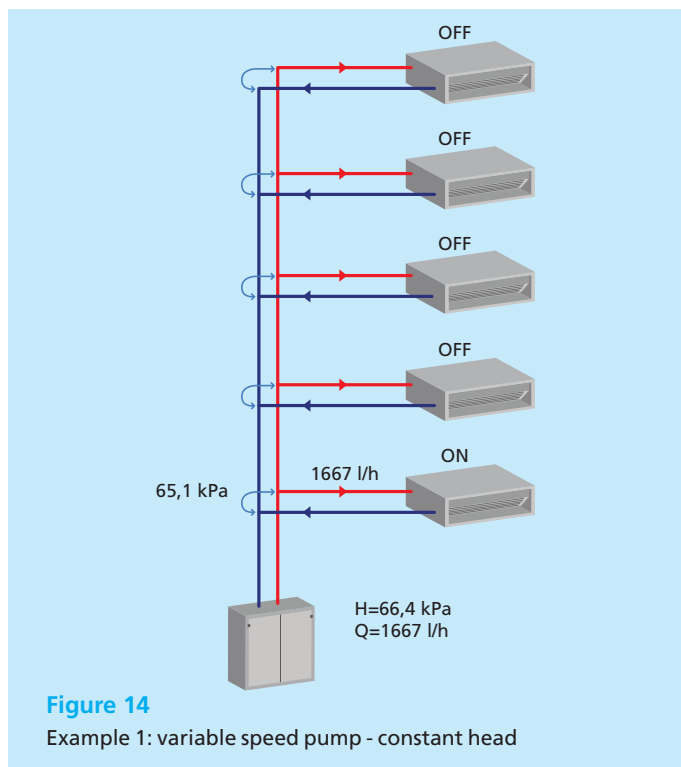
Manual adjustment is a simple and effective procedure even if there are limits: in variable volume systems a reduction in the flow rate in just one branch influences the flow rates in the remaining branches.

If we consider the extreme case in which all the devices are closed except the one closest to the circulator and that this doesn't have a speed adjustment (traditional pump), the resulting situation is shown in the drawing below (**Figure 13**).



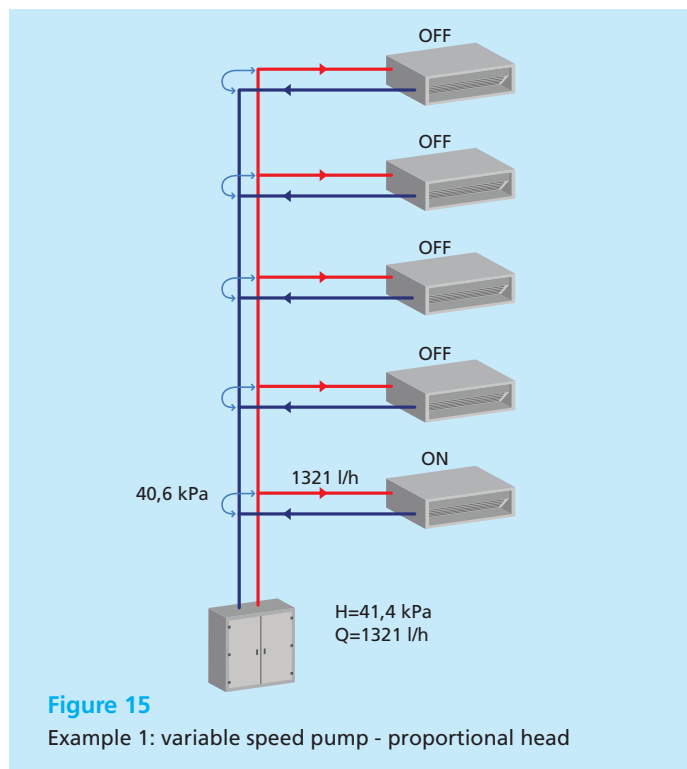
The flow rate is increased by 39.1% and the circulator consumes about 2.5 times more energy than is actually required.

If a variable speed pump is used and a constant head is maintained, which in this case is 66.4 kPa, we have the following situation (**Figure 14**):



The increase in the flow rate is only 16.9% and the power consumption of the pump is 60% higher than necessary.

And finally, introducing a proportional head controller, we obtain the following (Figure 15).



The flow rate is at 92.1% and the pump consumes 78.1% of the power.

From the simple distribution network that we analyzed we can conclude that:

Balancing can slightly reduce the energy used for the circulation of the heat-transfer fluid;

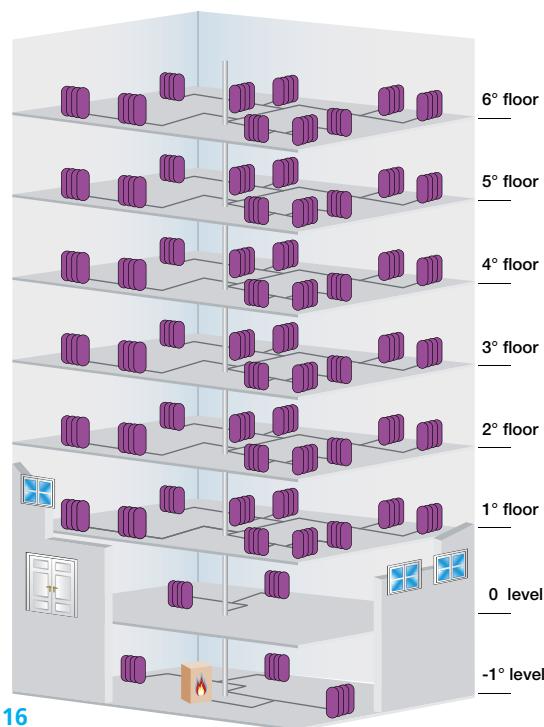
The manual valves balance the system in an effective manner when there are no closures or shuttering of the flows of the individual terminal branches; Variable speed pumps help reduce consumption but do not allow the entire system to be monitored. They must be used with devices installed at sensitive points in the network in order to correct any imbalances that the pumps can't detect on their own.

These devices are automatic valves that, as we will see in the following chapters, can resolve this problem.

**Table 2**  
Pumps technologies comparison

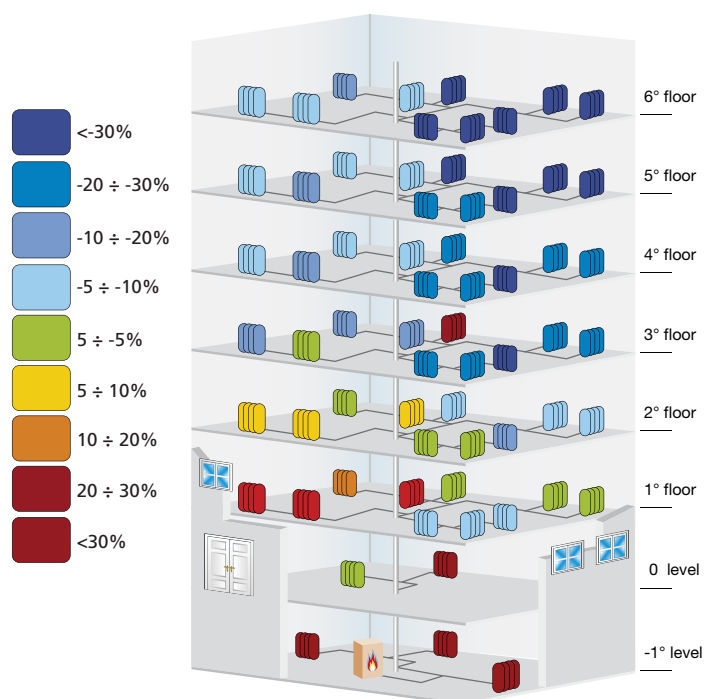
Technology	Flow rate	Power
Traditional	+39.1%	+169%
Constant head	+16.9%	+60%
Proportional head	-7.9%	-22%

But if we consider a medium size system, like that seen in Figure 16, the situation drastically worsens:

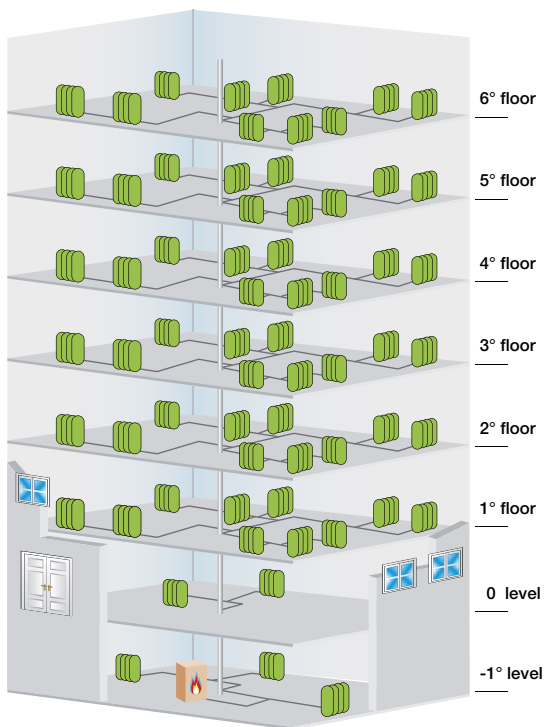


If the system is unbalanced (Figure 17) there is an extreme overcompensation, the terminal branches on the bottom floors are greatly over-supplied: they can even reach three times the design flow.

As you go up the floors the trend reverses, until you get to the top floors where there is a flow rate deficit that can be as much as 42.7%.

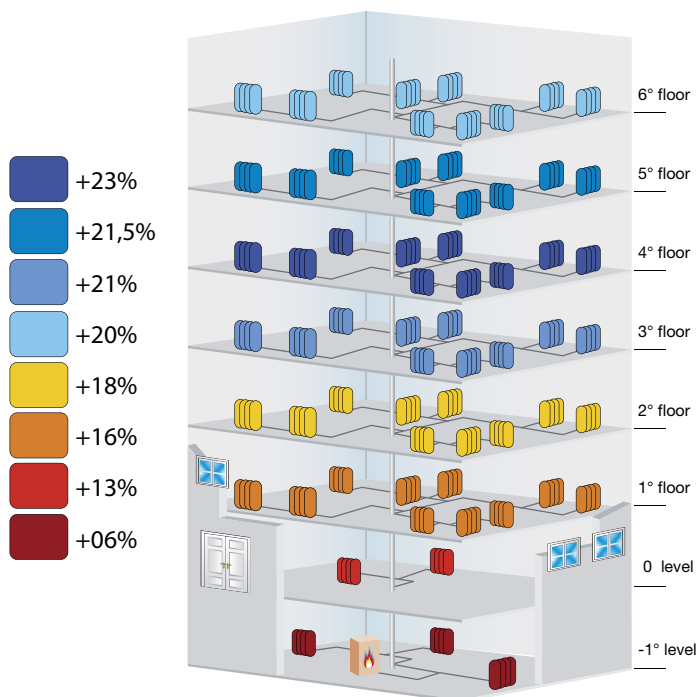


By regulating the system using balancing valves, we get the situation seen in **Figure 18**, where all the terminal branches receive the desired flow rate.

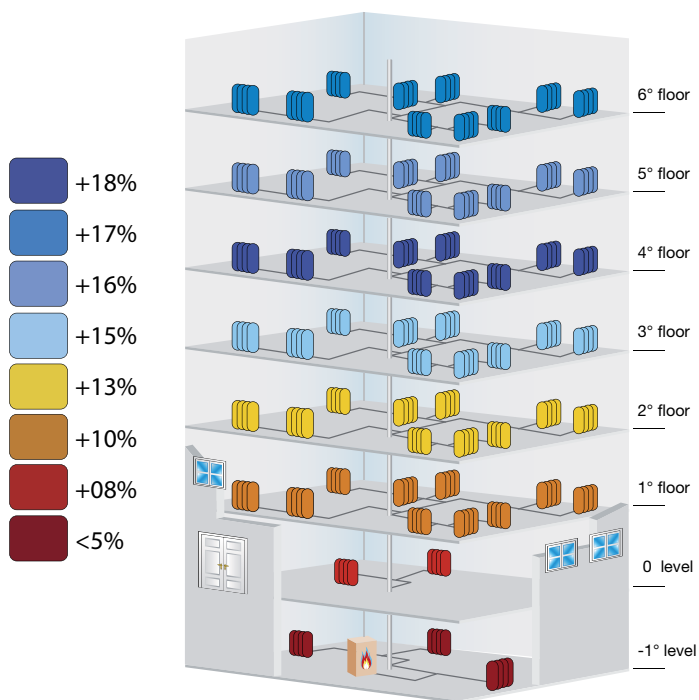


**Figure 18**  
Example 2: balanced system

In the case where the top floor of the building is completely shut off (**Figure 19**), with a traditional pump there would be a general increase in the flow rates with a peak of 23%.

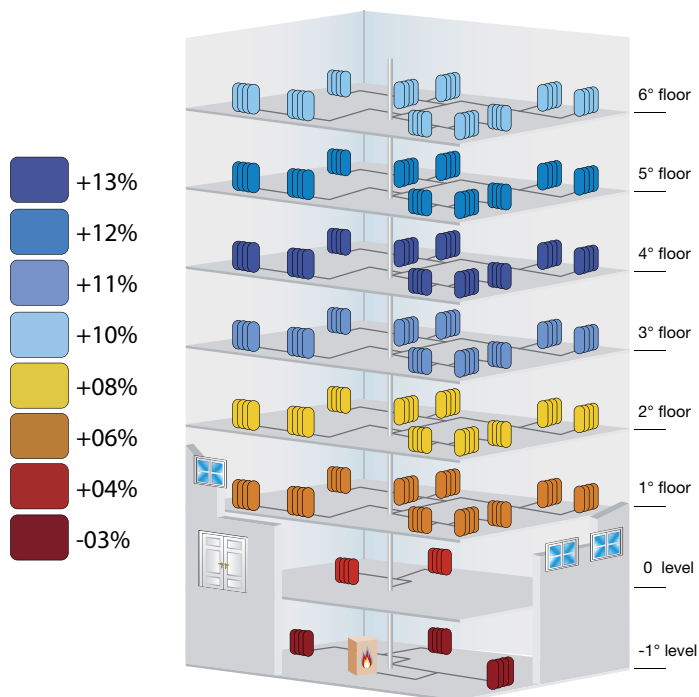


**Figure 19**  
Example 2: traditional pump



**Figure 20**  
Example 2: variable speed pump - constant head

The situation improves with a variable speed pump, and the error is 18% with constant head pumps (**Figure 20**) and 13% with proportional head pumps (**Figure 21**).



**Figure 21**  
Example 2: variable speed pump - proportional head



# Balancing Valves Handbook

## Regulating valves and flow measurement devices

### 3.1.2 - Double regulating valves

The installation of double regulating valves at appropriate points in the system is a basic requirement for effective system regulation. Purpose manufactured double regulating valves should always be specified; gate type isolating valves or full bore ball valves are not suitable for regulation.

Double regulating valves differ from ordinary regulating valves in that the flow setting is not lost when the valve is closed.

They can be regulated from fully open to the required flow setting position, and then locked at that position.

The valve may then be closed and reopened to the same setting. The body of the valve also features a dial indicating the setting of the valve.

This enables the user to record the setting for future reference **Figure 22**. Shows examples of Cimberio double regulating valves.

**cim 727**



**Figure 22**  
Double regulating valves



Double regulating valves: section

### 3.1.3 - Regulating 2-way control valve

They are 2-way valves with thermoelectric actuator which can be regulated by a switch installed below the head and are used in system branches where the flow rate needs to be regulated or cut.

The actuators can operate at different electrical voltages and can be normally open (N.O.), normally closed (N.C.) and proportional (input signal from 0 to 10 V).

**cim 788**



**Figure 23**  
Regulating 2-way control valve with actuator



Regulating 2-way control valve with actuator: section



# Balancing Valves Handbook

## Regulating valves and flow measurement devices

### 3.1.4 - Fixed orifice flow measurement devices

A simple orifice device is a circular metal plate with a centrally positioned orifice that produces a restriction in the fluid flow causing a pressure differential across the plate. This pressure differential can be used to calculate flow rate.

To achieve accuracy requires careful dimensioning of the orifice and associated pressure tapings. Therefore the use of manufactured fixed orifice fittings incorporating the necessary pressure tapings is recommended.

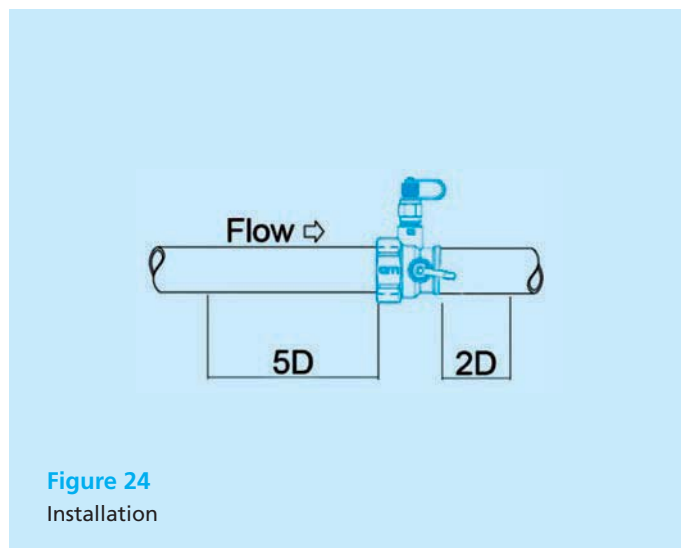
Fixed orifice devices are sensitive to upstream flow conditions. Fittings that distort the pattern of flow such as bends or restrictions will cause the flow measurement accuracy to deteriorate.

In order to achieve reliable flow measurement accuracy it is recommended that a straight section of pipe be installed upstream of each device measuring at least 5 pipe diameters in length (**Figure 24**).

Downstream conditions are less important and for heating/cooling applications can generally be ignored.

**Figure 25** shows examples of Cimberio fixed orifice devices.

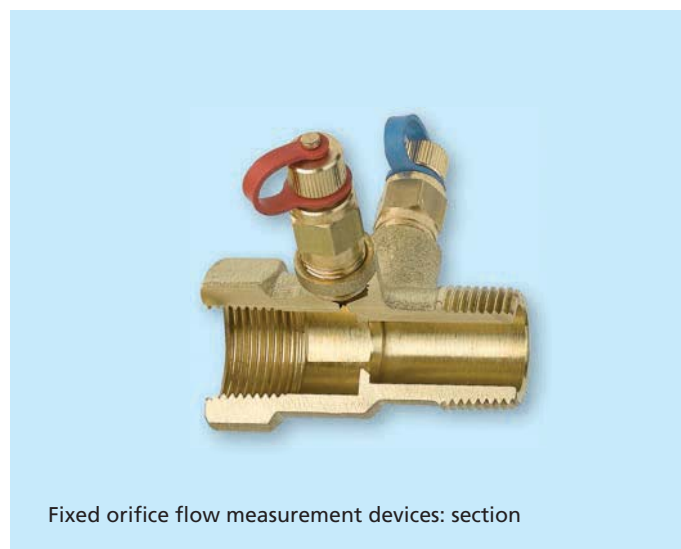
The accuracy of fixed orifice flow measurement devices is typically  $\pm 5\%$ .



**Figure 24**  
Installation



**Figure 25**  
Fixed orifice flow measurement devices



Fixed orifice flow measurement devices: section



# Balancing Valves Handbook

## Regulating valves and flow measurement devices

### 3.1.5 - Fixed orifice double regulating valves

The fixed orifice double regulating valve is a double regulating valve either close-coupled to a fixed orifice fitting, or with an integral fixed orifice as illustrated in **Figure 26**.

The flow measurement function is separated from the balancing function, they can be regulated to nearly closed positions, achieving excellent accuracy.

It permits flow measurement, regulation and isolation to be carried out at one location. The determination of the flow rate is obtained by reference to a single line pressure differential/flow rate chart.

The regulating valve is usually an oblique pattern globe

valve for smaller sizes or a butterfly type for larger pipe diameters.

Computational fluid dynamics software has been used to demonstrate the stable pressure and flow patterns across balancing valves at different settings (**Figure 27 and 28**).

The analysis shows that, due to the compact body of the valve, turbulent zones and eddy currents are minimised, thereby ensuring stable performance.

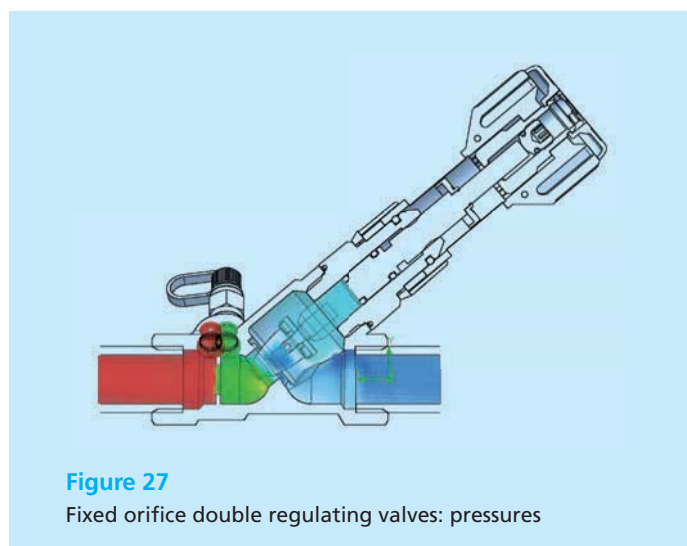


cim 747

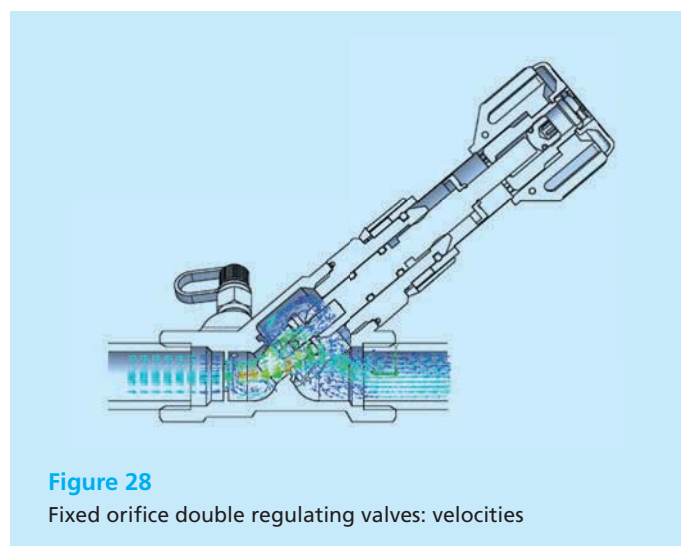
**Figure 26**  
Fixed orifice double regulating valves



Fixed orifice double regulating valves: section



**Figure 27**  
Fixed orifice double regulating valves: pressures



**Figure 28**  
Fixed orifice double regulating valves: velocities



# Balancing Valves Handbook

## Regulating valves and flow measurement devices

### 3.1.6 Variable orifice double regulating valves

Variable orifice double regulating valves differ from fixed orifice double regulating valves in that they use the pressure drop across the valve opening for flow measurement.

Hence the term variable orifice; for these valves there is a variable opening across which the pressure differential is measured.

The size of the opening varies depending on the valve setting.

Figure 30 shows variable orifice double regulating valves.

Variable orifice valves seldom achieve the accuracy and reliability of fixed orifice valves.

The precision can deteriorate creating flow measurement distortions beyond a certain closure point.

In order to avoid commissioning problems, the use of this valves should be limited to situations where the valves will not need to be throttled below 25% open.

Figure 30 and 31 show the distribution of pressures in the valve and the flux of velocities.

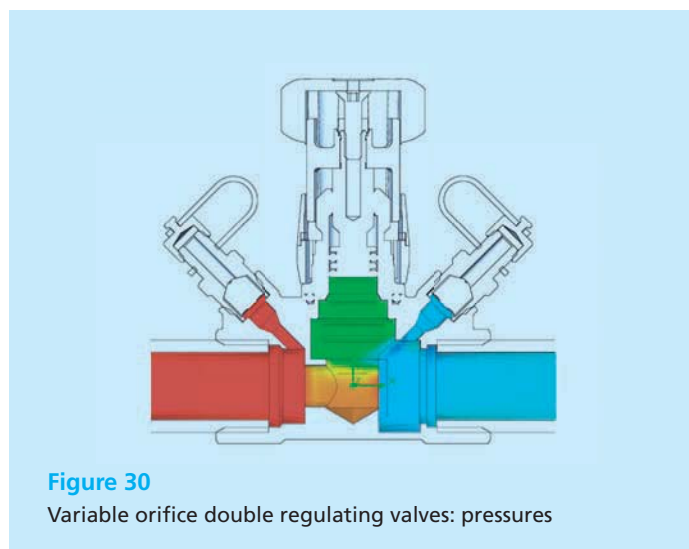


**cim 787**

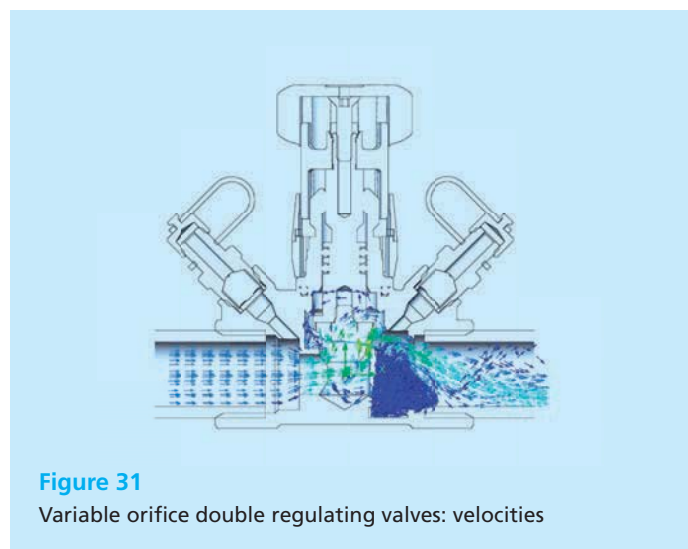
**Figure 29**  
Variable orifice double regulating valves



Variable orifice double regulating valves: section



**Figure 30**  
Variable orifice double regulating valves: pressures



**Figure 31**  
Variable orifice double regulating valves: velocities





# Balancing Valves Handbook

## Regulating valves and flow measurement devices

### 3.2 Fixed orifice versus variable orifice

#### 3.2.1 Flow measurement accuracy

The fixed orifice pattern of valve is able to maintain far higher levels of flow measurement accuracy and repeatability than the variable orifice valve for the following reasons:

■ **The orifice is fixed:**

for a fixed orifice valve, as implied by the name, the orifice does not change. There is therefore a single kvs value for the flow measurement device and hence a single line graph of flow rate versus pressure drop. Because the orifice is fixed and has no moving parts, its accuracy can be guaranteed at any degree of valve closure. The accuracy of a fixed orifice device can be maintained within  $\pm 5\%$  no matter what the setting of the attached double regulating valve. For a variable orifice valve the valve setting and hence orifice dimension will vary so that a different kvs value is required for each valve setting. As the valve closes the area open to flow becomes very small. When the valve is nearly closed it becomes very difficult to ensure fixed and repeatable kvs values across all products. As a result, some variable orifice valves exhibit a gradually deteriorating flow measurement accuracy (of up to  $\pm 12\%$  or worse), as the valve is closed.

■ **Accuracy is unaffected by system dirt:**

most heating and cooling systems will contain circulating particles of material which entered the system during installation. Such material could include dirt, sand, jointing materials, or where steel pipes are used, corrosion debris.

■ For a fixed orifice valve, such material is unlikely to block the circular opening of the orifice.

■ Orifice sizes for the smallest valves are at least 4 mm in diameter, which is enough to allow most debris through. Hence, flow measurement accuracy is usually unaffected by circulating dirt particles.

■ For a variable orifice valve that is partially closed, dirt can become trapped around the plug of the valve causing the valve resistance to increase. Small diameter valves that are partially closed (50% or less) may have openings of less than 0.5mm around the valve plug which make them very susceptible to blockage.

■ If a valve is partially blocked then a higher than normal pressure drop signal will be indicated across its tappings suggesting to the user that the flow rate through the valve is much higher than it actually is. If the valve has a minus 12% error under clean water conditions, this could increase to minus 20% or more in real systems with circulating dirt. The problem persists even when the valve is completely blocked. A pressure differential may still exist across the valve suggesting that there is flow when in fact, there is none at all.

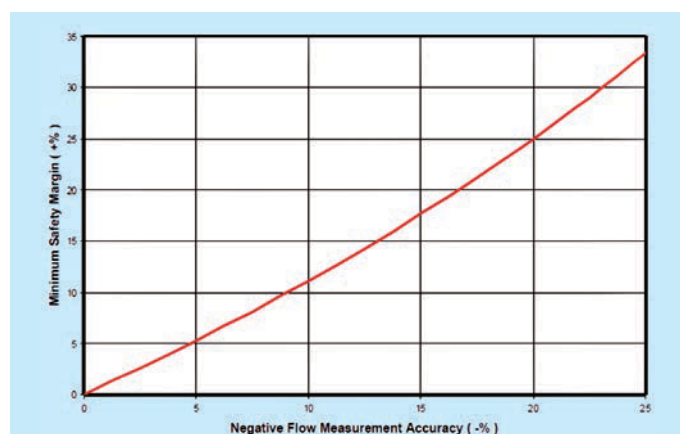
#### 3.2.2 Why flow measurement accuracy is important

The importance of flow measurement accuracy is sometimes ignored on the grounds that many types of heating or cooling emitters are relatively insensitive to flow rate variations. However, inaccurate flow measurement has a significant impact on plant sizing and energy consumptions, as can easily be demonstrated.

Suppose that the minimum acceptable cooling heat transfer for a particular situation was 10 kW and that anything less than this would lead to under-cooling of the room or zone.

This kW load at a 6 degree  $\Delta T$  gives a flow rate of 0.40 l/s. Hence, any flow rate less than 0.40 l/s could result in under-cooling. However, if when it comes to measuring this flow, the accuracy of measurement is potentially minus 20% (as could be the case using a partially blocked variable orifice valve), then a safety margin must be added to the original load and flow rate to allow for this.

Applying the same logic to a range of estimated flow measurement accuracies, one can establish the graph shown in **Figure 32**.



**Figure 32**

Impact of flow measurement accuracy on heating and cooling safety margins



# Balancing Valves Handbook

## Regulating valves and flow measurement devices

It can be seen that if flow measurement accuracy can be improved to better than minus 5%, which is the case for fixed orifice valves, then the required safety margin on flow rate and kW output need only be just over 5%. This represents a far more acceptable level of risk for the performance of the system.

### 3.2.3 Conclusion

It can be concluded that in the past, many systems have been designed with significant safety margins that have allowed successful system performance even though flow rates were not accurately measured and set. However, this has been at the expense of over-sized heating and cooling plant and consequent waste of energy. In view of the tightening requirements on installed cost and energy consumption, it can no longer be assumed that heating and cooling loads will incorporate healthy safety margins which can be used to offset the consequences of inaccurate flow measurement.

There is now a clear need for flow balancing and measurement devices that give as high an accuracy as possible, and for a procedure that ensures that an accurate balance is achieved. In this respect, fixed orifice regulating valves have major advantages over variable orifice regulating valves.

### 3.3 Automatic balancing valves

An automatic balancing valve has an automatic device that maintains a constant flow in hydronic systems when there are pressure fluctuations. They are used in both constant volume systems and in variable volume systems.

#### 3.3.1 Constant Flow Regulator

These are the simplest automatic valves and they maintain a constant flow which is set through the choice of an appropriately sized cartridge. Every cartridge has a corresponding flow rate and recognition code and these values are reported on the valve's label.

The operating principle is fairly simple: observing **Figure 33** we see that the flow enters the lower part of the cartridge, where there is a calibrated hole.

When passing, the fluid opposes a thrust which balances the spring inserted inside the cartridge. The balancing of the hydraulic thrust - force and the response of the spring is such that it conditions the opening of the outlet.

There is however a system operating limit. If the pressure is not high enough, the spring contracting force would be too high and the valve would remain fully open.

The minimum opening differential pressure is approximately 15-20 kPa and depends on the type of cartridge. This is part of the valve's characteristic data and is called the start-up pressure.

For large water networks, numerous cartridges can be combined inside one wafer body, thus creating an automatic balancing valve having the same flow rate as the sum of the flows of the individual cartridges.

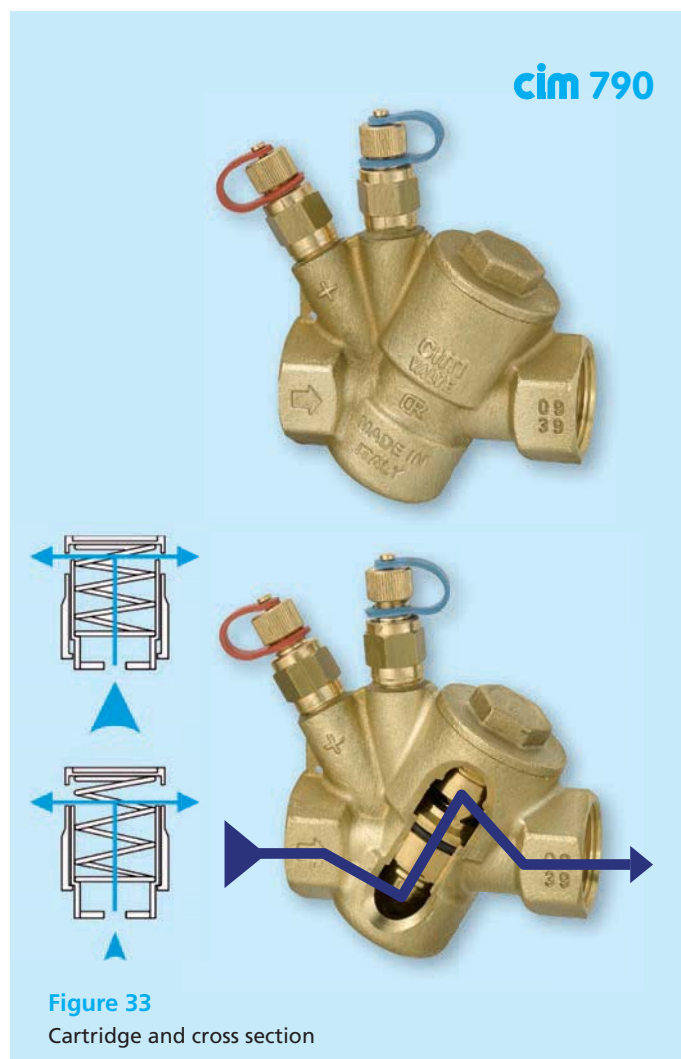


Figure 33  
Cartridge and cross section

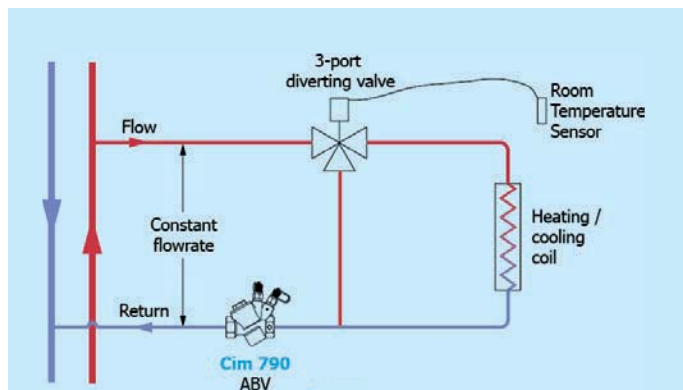


# Balancing Valves Handbook

## Regulating valves and flow measurement devices

CFR's can be installed in constant volume systems. A typical diagram is given in **Figure 34**.

As can be seen, the system is controlled using a diverting/mixing valve that deviates the flow in a hydraulic short circuit, by-passing the emitters.



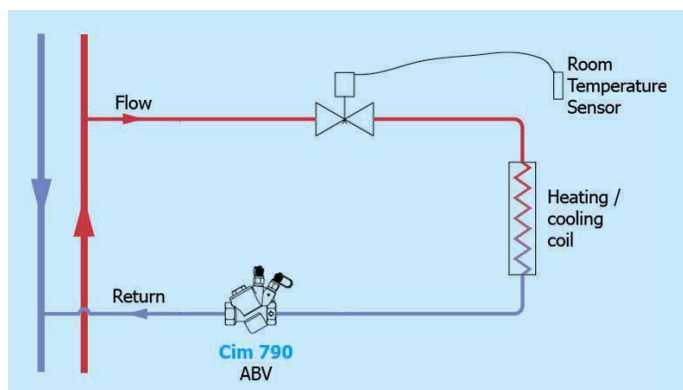
**Figure 34**  
CFR in constant volume systems

By installing a CFR in the return branch - generally subject to less heat stress - the flow rate in the branch will remain constant in any situation.

The same diagram can be used for systems with a mixing valve.

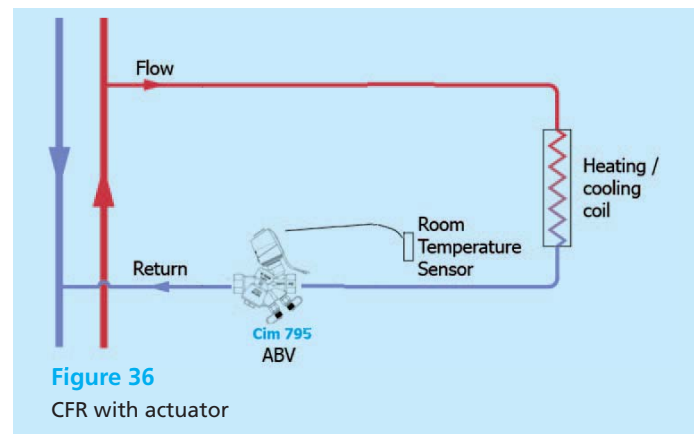
CFRs can also be used with variable speed pumps in constant volume systems, using an actuator, generally a 2-way control valve (regulating valve with thermoelectric actuator). The flow in the branch can be stopped when the desired temperature is reached.

In this way the branches that are still open will not be affected by flow rate variations.



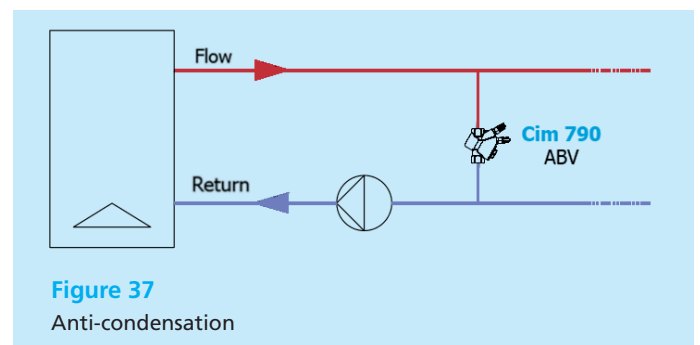
**Figure 35**  
CFR in variable volume systems

As seen in the figure below, automatic valves with thermoelectric actuators for controlling the opening and closing of the flow are also available:



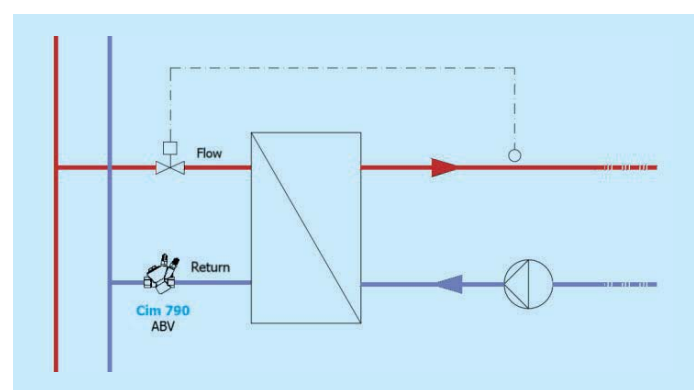
**Figure 36**  
CFR with actuator

The valve can also be used as an anti-condensation system, where a minimum return temperature to the boiler is typically required in biomass systems. This condition can be guaranteed by inserting an appropriately sized automatic valve.



**Figure 37**  
Anti-condensation

A CFR can be inserted in satellite systems in order to increase the system's energy efficiency rating. The valve can be installed at the primary outlet of the heat exchanger.



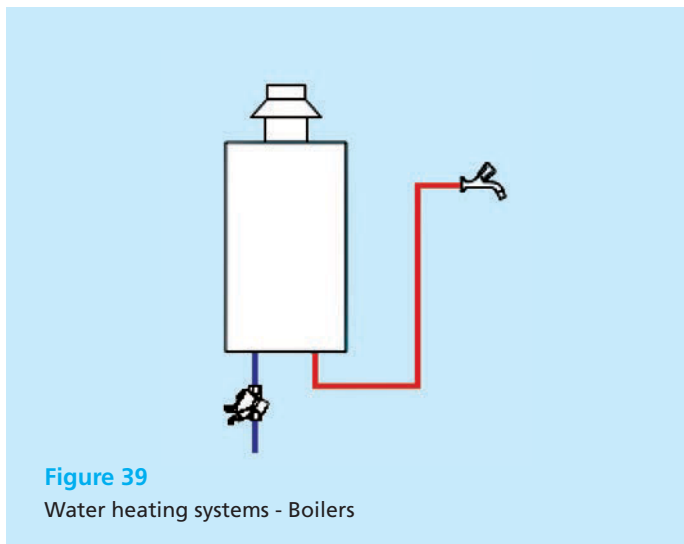
**Figure 38**  
CFR with heat exchanger



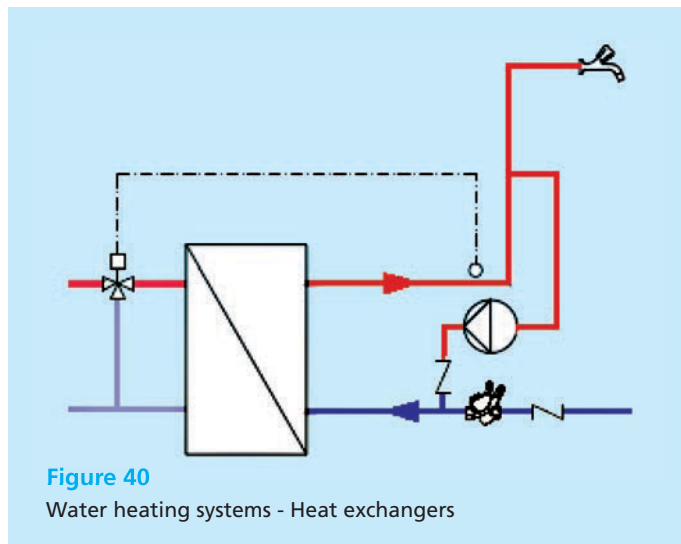
# Balancing Valves Handbook

## Regulating valves and flow measurement devices

The valve can also be used as a flow restrictor in sanitary hot water systems. As illustrated below:



**Figure 39**  
Water heating systems - Boilers



**Figure 40**  
Water heating systems - Heat exchangers

### 3.3.2 Differential Pressure Control Valves

These valves control a different physical property than the previous others: the differential pressure between two points in the system.

Using a DPCV ensures a constant head in all the branches that the valve is connected to.

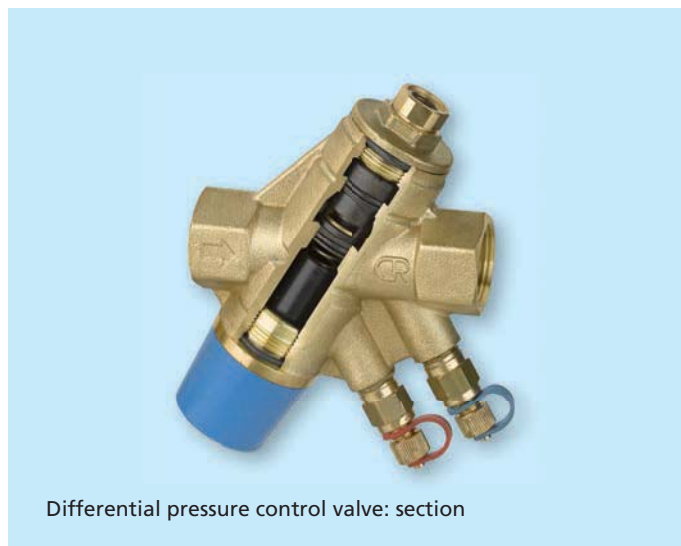
As mentioned previously, a DPCV needs to be installed in medium-large size systems: variable speed pumps are not able to control an extensive system since they are generally installed in remote locations with respect to the users.

They are typically installed at the base of the riser tubes, as shown in **Figure 43**, in buildings with only a few floors above ground, or directly in the floor branches for tall buildings (**Figure 44**).

This last type of installation is used to obtain an excellent regulating valve authority: a branched circuit sufficiently close to the pump, subject to a fairly high differential pressure is considered.



**Figure 41**  
Differential pressure control valve



Differential pressure control valve: section



# Balancing Valves Handbook

## Regulating valves and flow measurement devices

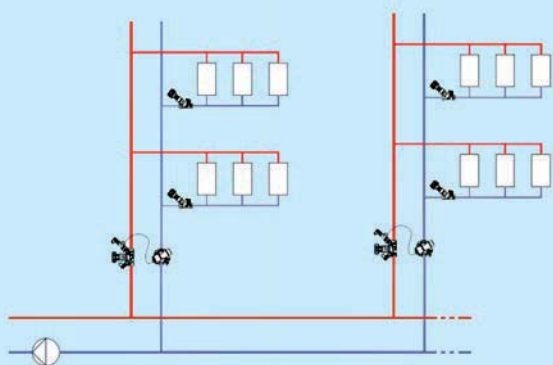
**cim 771**



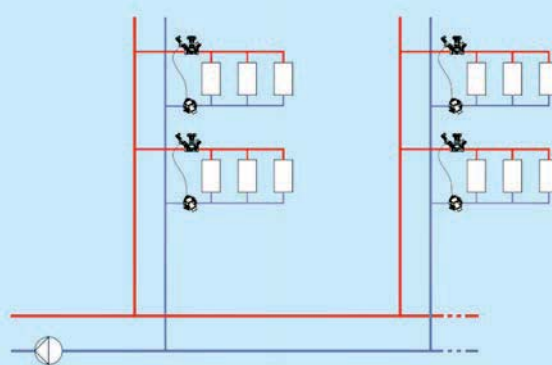
**Figure 42**  
Electronic differential pressure control valve



Electronic differential pressure control valve: section



**Figure 43**  
Differential pressure valve on the riser



**Figure 44**  
Differential pressure valve on the manifold



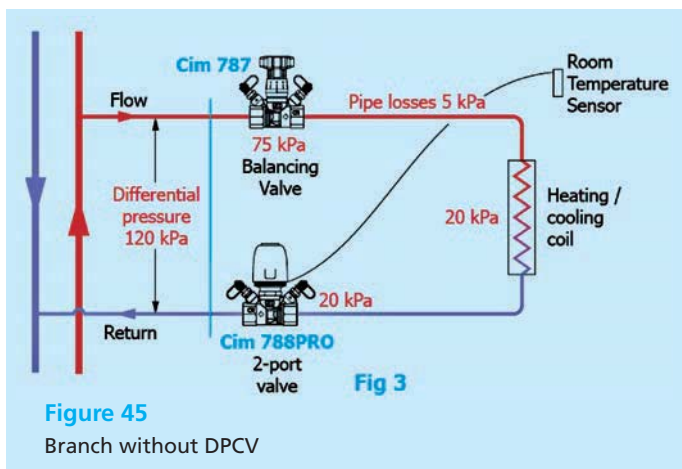
# Balancing Valves Handbook

## Regulating valves and flow measurement devices

As noted, the valve authority is defined as:

$$\beta = \frac{\Delta p_{\text{valve}}}{\Delta p_{\text{total}}}$$

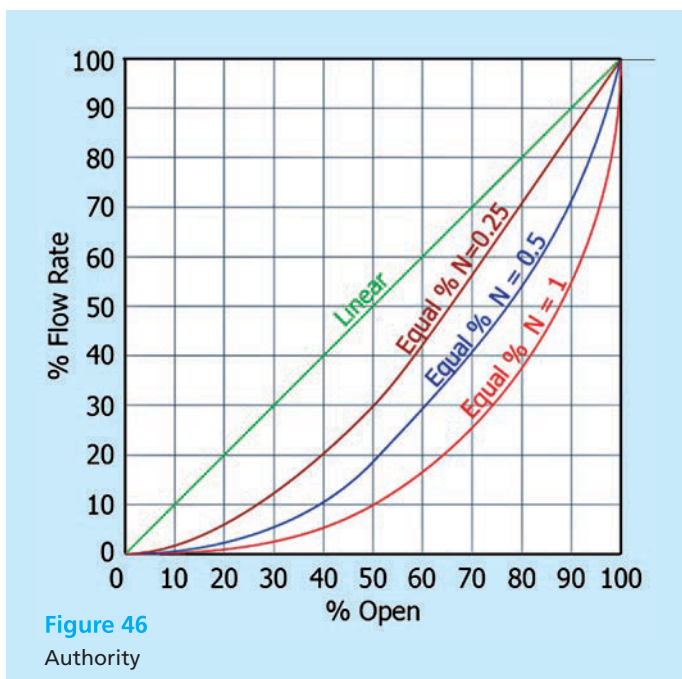
Where  $\Delta p_{\text{total}}$  is intended to be the total pressure drop of the concerned circuit to be regulated, including that of the valve (2-way control valve, thermostatic valve).



The 2-way control valve has a modest pressure drop with respect to the circuit to be controlled, and the authority value is:

$$\beta = \frac{\Delta p_{\text{valve}}}{\Delta p_{\text{total}}} = \frac{20}{120} = 0.167$$

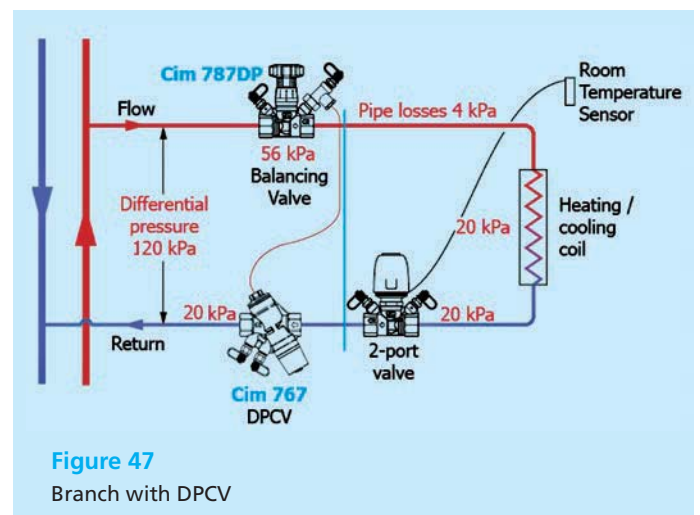
The valve has almost linear characteristics, as seen in the graph:



For the valve to effectively perform the regulation action it must have authority in the circuit to be controlled, or rather it must create a pressure drop that is comparable to that of the rest of the circuit to be regulated.

A low authority causes a linear variation to the flow rate with opening of the stem, while a high authority (>0.5) causes a non-linear percent type opening.

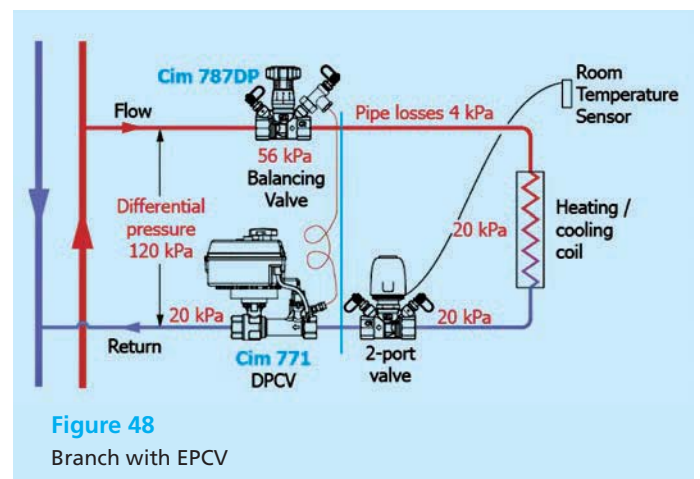
Now let's consider the same circuit with a differential pressure control valve installed and the  $\Delta p$  set at 44 kPa.



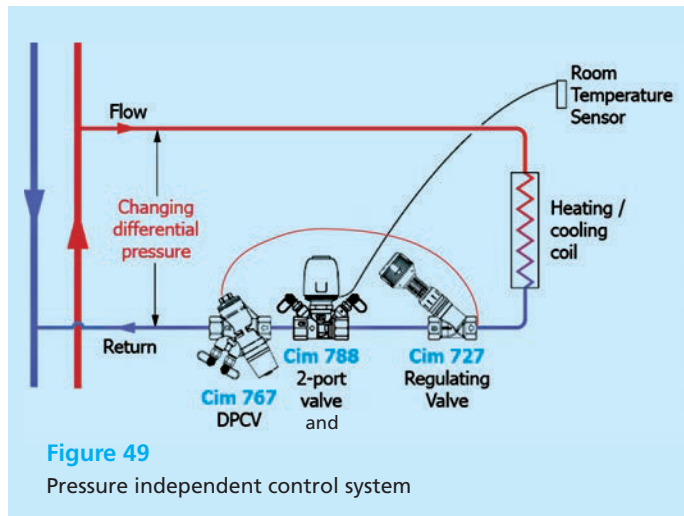
In this situation the circuit to be controlled will always be subject to the same differential pressure, but what's more important is that the 2-way valve will have an elevated authority:

$$\beta = \frac{\Delta p_{\text{valve}}}{\Delta p_{\text{total}}} = \frac{20}{20+24} = 0.455$$

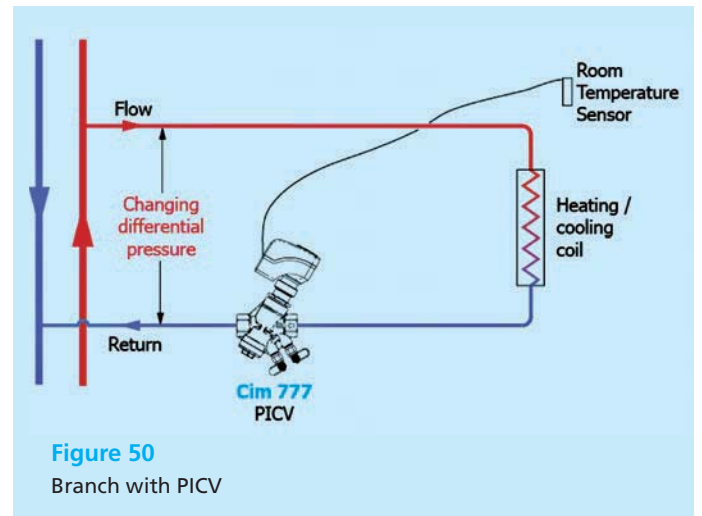
The same holds true for electronic valves:



The previous diagrams show a two-way valve for controlling the flow, a regulating valve and the DPCV to regulate the maximum flow rate and to adjust it based on the capacity to transmit to the climatized rooms. Working out the position of the components used, we can get a diagram like this:



The previous diagrams show a two-way valve for controlling the flow, a regulating valve and the DPCV to regulate the maximum flow rate and adjust it based on the capacity to transmit to the climatized rooms. Working out the position of the components used, we can get a diagram like this:



### 3.3.3 Pressure Independent Control Valves

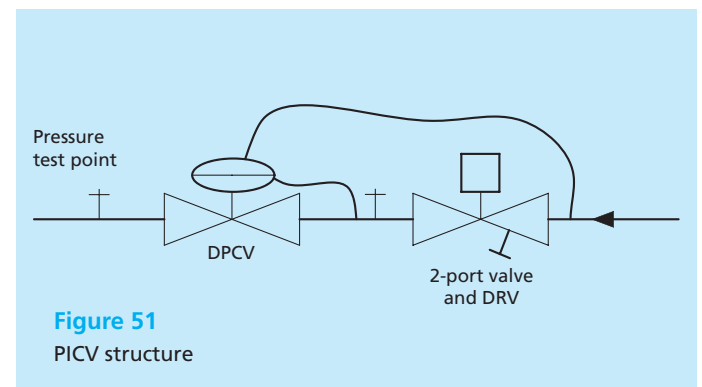
As mentioned in the previous paragraph, the PICVs are a combination of three valves:

- DPCV;
- Regulating valve;
- 2-way control valve.

The structure of the valve can be seen in the figure.

The fluid passes through the adjustable opening of the modulating control component and acts against the push of the spring installed in the cartridge, balancing the force and changing the section of the outlet holes.

Using the actuator or the manual command, the flow rate can be shuttered based on the needs.





# Balancing Valves Handbook

## Regulating valves and flow measurement devices

### 3.3.3.1 Operating principles

#### Regulation

When the electric actuator or plastic cap is missing, the valve is normally closed by a swing. On the contrary, if the plastic cap is screwed or the electric actuator installed therein, they win the force of the swing and open the valve (see picture). The inlet water goes through a modulating control component whose geometry can be modified by turning the presetting dial, according to the required flow rate in the system branch where the valve is installed.

#### Control

Two different pressures operate on the DPC cartridge. The first one is transmitted through the passage connecting the valve inlet to the lower section of "p+" cartridge (see hydraulic scheme picture 46); the second one is registered at valve outlet by the flow rate selecting device "pa". In order to keep constant the difference between the mentioned pressures, the DPC cartridge obturator operates by closing the water outlet bore to reach the preset flow rate, regardless of fluctuating pressure conditions of the system.

#### Modulation

The electrical actuator performs the modulating function changing the section of flow passage. When continuous modulation is carried out, the temperature is kept under control. The valve keeps the same obturator stroke, regardless of the presetting dial position. With continuous modulation, control is excellent even with small flow opening. This eliminates the on/off effect.

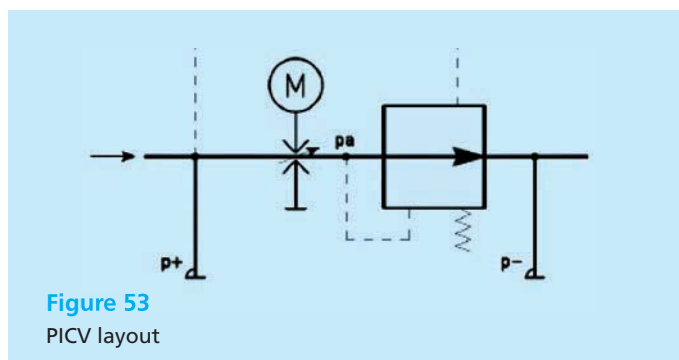


Figure 53  
PICV layout

The graph below shows the characteristic curves of a PICV for the various preset positions.

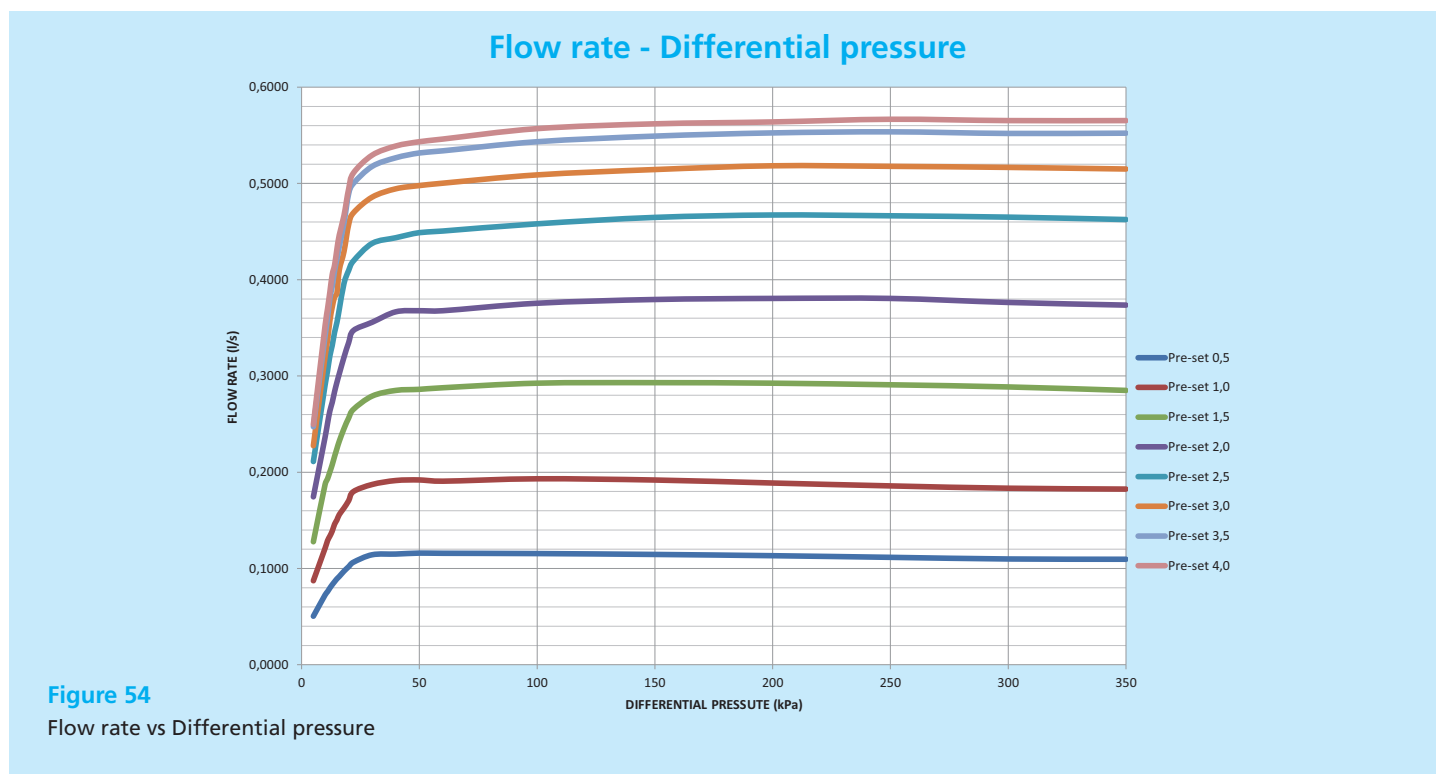


Figure 54  
Flow rate vs Differential pressure





# Balancing Valves Handbook

## Design considerations

### 4. Design considerations

#### 4.1 Self-balancing arrangements

By careful sizing of pipes, flow rates can be made to approximately achieve a self-balance. A self-balancing arrangement will reduce the time required to regulate branch flow rates and will often make it unnecessary to balance flows through terminal units. However, there are usually cost and performance penalties that must be taken into consideration when attempting this solution.

The self-balancing characteristics of a pipe distribution system may be improved by considering the following design options:

##### Reverse return

A simple reverse return layout is shown in **Figure 55**. In order for this type of system to self-balance, each of the terminal circuit pressure drops must be equal. Hence each circuit requires identical terminal units and similar pipe lengths and fittings.

Furthermore, opposing pressure losses in the flow and return mains must also be kept as similar as possible. For example if the pressure loss in AB varies significantly from the pressure loss in CD then the self-balancing properties may be lost.

Reverse return systems invariably involve extra pipe work

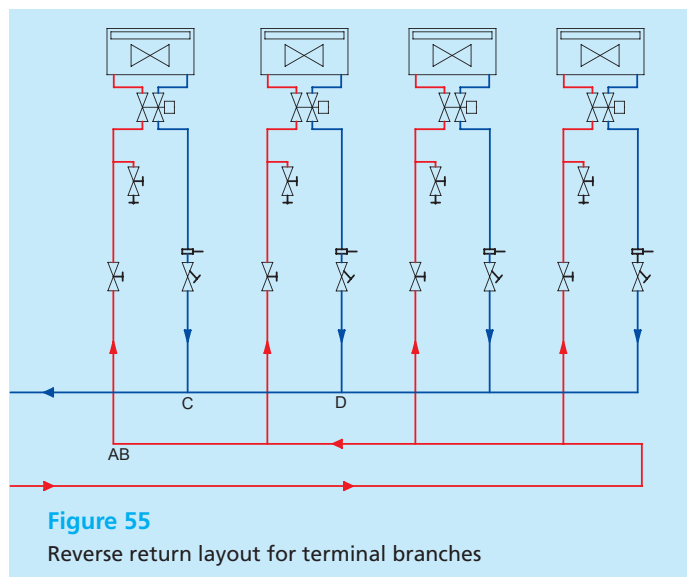


Figure 55

Reverse return layout for terminal branches

since a longer run of return pipe is required to complete the circuit. This can increase the overall cost of the system and increase system resistance leading to higher pump energy consumption.

It is therefore important to ensure that the use of reverse return systems can be economically justified in comparison with a conventional layout with regulating valves.

##### Low loss headers

In circuits based on low loss headers the idea is to keep the pressure loss in the mains as low as possible so that the pressure differential available to each circuit is roughly the same.

In order for this arrangement to work the terminal devices have to be identical i.e. the same flow requirement and the same resistance to flow rate. Low loss headers require that pipe circuits are sized one or two sizes larger than would normally be the case.

##### Calibrated valves

It is possible to calculate the theoretical pressure loss required across a regulating valve in order to regulate the flow rates in the system. From these values the individual settings of each regulating valve can be predicted, thereby avoiding the need for a proper flow balancing procedure.

In practice, any balance achieved in this way is likely to be extremely crude with the potential for large variations in flow rate. This is because the theoretical resistances of components are not very accurate and the manufacturer's pressure loss data may not always be up to date.

##### Manifold Distribution

Manifold distribution encourages self-balancing by creating roughly equal pressure losses across each circuit. The pressure differential across each circuit is the same because the manifold ports are very close together. In order to take advantage of this property, the supplied terminal circuits must again be as similar as possible i.e. identical terminal units and similar pipe lengths.



# Balancing Valves Handbook

## Design considerations

### 4.2 Velocities

Flow velocities will be determined by the chosen range of acceptable pressure drops per metre of pipe length (typically between 100 and 350 Pa/m for main distribution branches). However, it is desirable to achieve velocities within the range of the recommended values given in **Table 2**.

**Table 2**  
Recommended range of water velocities

PIPE DIAMETER (mm)	VELOCITY (m/s)		
	Minimum	Maximum	
	Copper/Steel	Copper	Steel
15-50	0.6	1.0	1.5
OVER 50	1.25	1.5	3.0

Excessive flow velocities may give rise to noise generation and erosion of system components.

Very low velocities may reduce the accuracy of flow measurement devices and could fail to prevent the occurrence of static air pockets in the system.

### 4.3 Pump selection

The design of a multi-circuit water distribution system should include a calculation of each circuit's resistance at the design water flow rate. The circuit that is predicted to present the greatest resistance is known as the index circuit. Usually, but not always, this is the circuit serving the terminal units located furthest from the pump source. A pump should be selected to operate within the stable part of its characteristic, and be capable of producing between 110% and 115% of the total design flow against the estimated index circuit resistance.

### 4.4 Variable speed pumps

It is sometimes argued that systems which use variable speed pumps and 2-way control valves do not require flow regulation. The belief is that once the 2-way valves begin to close down, any flow balance achieved when the system was fully open will be lost.

Furthermore if system flow rates are out of balance then the system will gradually self-compensate, since high flow regions will heat up or cool down more quickly; then, when the 2-way valves close down, flow will increase in parts of the system that were originally starved of flow.

In reality this argument does not hold up. A system with unbalanced flows will take much longer to reach design temperatures. Areas that are receiving too much flow will not reach their design temperatures very much faster than if the flows were correct.

This is because the heat transfer across most emitters is relatively insensitive to large increases in flow rate. Hence the flow could be double its design value but the heat transfer may only be 10% more. The consequence would be a system that would take much longer to achieve uniform temperatures around the building and which would need to operate for much longer periods.

### 4.5 System cleanliness

Dirt in the system can adversely affect the accuracy of flow measurement devices and therefore system cleanliness is of prime importance. Adequate facilities must be built-in at the design stage so that the system can be flushed to remove dirt and jointing materials. Where appropriate, strainers should be located to trap circulating dirt particles before they reach small diameter regulating valves and control valves.

### 4.6 Venting and draining

Air trapped within a pipework system can present serious problems during regulation by distorting measured flow rates. These distortions may be due to pump surging, causing rapidly varying flow rates, or air binding of terminal units causing apparent blockages. Alternatively, system air may cause false readings at flow measurement devices due to air pockets in the pressure tapping points.

Features must be built into the pipework system to enable all the air to be vented. These features can take the form of air bottles, with either manual or automatic air vents, or simple air cocks at the high points in the system and at all plant items and terminal units.



# Balancing Valves Handbook

## Guidelines for valve selection

### 4.7 Access

Adequate space is necessary, not just for installation but also to permit access for commissioning and maintenance. Attention should be given at the design stage to ensure that service ducts and architectural features, such as false ceilings, will be compatible with the anticipated degree of accessibility.

Access to flow measurement devices and regulating valves should be a prime consideration. In particular:

- at least 100 mm clearance from pressure test points must be allowed to enable the manometer tubes to be connected without bending;
- access to double regulating valves must be such that scales and markings are clearly visible;
- the thickness of pipework and ductwork insulation, and the support and bracketing arrangements must be anticipated;
- the positions of access panels in false ceilings, etc. must be properly co-ordinated with the flow measurement device and regulating valve positions.

## 5. Guidelines for valve selection

The following general guidelines are provided to assist the designer in the selection and application of flow measurement devices and regulating valves.

### 5.1 Terminology

When selecting valves it is helpful to understand the common terminology that is applied to regulating valves. In particular kv values and kvs values.

#### Kv

The kv value represents the flow rate through a fully open valve at a temperature between 5°C and 40°C, and measured in cubic metres per hour that will induce a pressure loss of 1 bar (100kPa). Hence the kv value is effectively a measure of the valve's resistance.

Where a valve is close coupled to a flow measurement device, the kv value represents the resistance across the fully open valve and flow measurement device combined.

Using SI units, the pressure drop across a fully open valve can be calculated from the equation:

Equation 1

$$\Delta p = 1.296 \cdot 10^6 \cdot \left( \frac{Q}{kv} \right)^2$$

where Q = flow rate in l/s, and  $\Delta P$  = pressure loss in Pa.

kv values express resistance as an inverse - in other words the greater the valve's resistance the smaller its kv value. Design engineers are more used to thinking of resistance in terms of the pressure loss coefficient (zeta). The pressure loss through any fitting or component can be calculated from the equation:

Equation 2

$$\Delta p = \zeta \cdot p \cdot \frac{v^2}{2}$$

where p = fluid density in kg/m<sup>3</sup>, v = velocity in m/s and  $\Delta P$  = pressure loss in Pa.

The higher the pressure loss coefficient, the greater the resistance of the fitting. For convenience, this guide expresses fully open valve resistances in terms of both kv and values based on velocities in mild steel pipes.

#### Kvs

This term applies to the pressure differential across the tappings on a flow measurement device. The "s" denotes "signal", since it relates to the pressure loss signal measured by the commissioning specialist. For a given flow measurement device with a known kvs value the commissioning specialist can calculate flow rate from the pressure loss signal using the following equation:

Equation 3

$$Q = \frac{kvs}{36} \cdot \sqrt{\Delta p}$$

where Q = flow rate in l/s, and  $\Delta P$  = pressure loss in kPa

(the overall pressure drop through the device). Because there is an increase in static pressure downstream of the orifice, the overall pressure loss is actually less than the measured pressure drop across the tappings. To determine the overall pressure loss through a flow measurement device, use its pressure loss coefficient ( $\zeta$ ) in Equation 2.



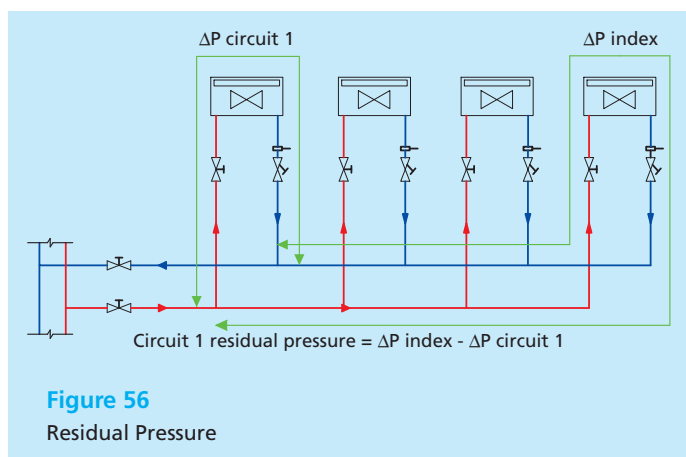
# Balancing Valves Handbook

## Guidelines for valve selection

### 5.2 Selection criteria

When sizing fixed orifice double regulating valves, the following issues should be taken into consideration.

1. Valves should be sized to match the size of the adjoining pipe whenever possible. Cimberio regulating valves are designed to accommodate standard flow ranges for given pipe sizes. Dropping to a smaller than line size valve could risk high pressure losses and excessive velocities through the valve.
2. Prior to sizing the flow measurement device, the type of instrument to be used for measuring the pressure differential must be considered and the upper working limit specified accordingly. The ranges of typical instruments commonly used for measurement of pressure differentials, are as follows:
  - a. mercury manometer: 1 to 65 kPa or 0 to 125 kPa;
  - b. fluoro-carbon manometer: 1 to 4.6 kPa or 0 to 8.8 kPa;
  - c. differential digital manometer/flowmeter: 1 to 150 kPa.
3. Flow measurement devices should be selected and sized to meet the following requirements at the design flow rate:
  - a. the minimum pressure: differential signal should be not less than 1 kPa;
  - b. double regulating valves should be selected to ensure that the required pressure drop occurs at valve settings not less than 25% open (to minimise the risk of dirt blockage).



**Figure 56**  
Residual Pressure

### 5.3 Selection procedure

1. Produce a system schematic diagram illustrating how the pipes interconnect to provide fluid flow to each terminal unit.
2. From heating and cooling load calculations, determine the design flow rates for all parts of the system.
3. Identify suitable locations for double regulating valves. Valves must be provided in the system wherever it is necessary to adjust the flow rate. This will usually include the following locations:
  - a. primary headers, main risers, branches and sub-branches;
  - b. terminal branches;
  - c. by-passes from 3-way control valves;
  - d. pump sets;
  - e. boilers and chillers (especially where units are in parallel);
  - f. zone control circuits incorporating a secondary pump.
4. From the valve selection table (see the example in **Table 4**), select the valve whose minimum flow rate is closest to, but less than, the design flow rate.

If pipes have been sized in accordance within normal velocity and pressure loss limits, then the selected valve will have the same diameter as the adjoining pipes.

**Table 4**  
Valve selection table DN15

DN (mm)	Minimum flow rate (l/s)	Model	Maximum Balancing Pressure (kPa)	kv	kvs	
15	0.015	721L	–	414.6	–	0.473
	0.028	721M	–	92.1	–	0.976
	0.055	721S	–	21.9	–	1.799
	–	727L	542000Q <sup>2</sup>	65.8	1.278	–
	–	727S	2366Q <sup>2</sup>	7.1	3.905	–
	0.015	737L	542000Q <sup>2</sup>	480.4	0.473	0.473
	0.028	737ML	542000Q <sup>2</sup>	157.9	0.825	0.976
	0.028	7737S	2366Q <sup>2</sup>	100.4	1.035	0.976
	0.055	721	2366Q <sup>2</sup>	29.4	1.911	1.799



# Balancing Valves Handbook

## Guidelines for valve selection

5. Having selected the valves, calculate the pressure losses across those valves in the index circuit. These pressure losses need to be taken into account when sizing the pump. To calculate the pressure drop across the fully open valve use the equations provided under section 5.1 above.
6. For those valves that are at the beginning of branches or which are close to the pump, check that the design pressure losses across them will not exceed their maximum balancing pressure. The design pressure drop across each valve is sometimes referred to as the residual pressure and is the difference between the pressure drop around the furthest branch and the one in question. **Figure 56** explains how residual pressure can be calculated.
7. Having calculated the required residual pressure, check that its value is less than the valve's maximum balancing pressure. The maximum balancing pressure is the pressure drop across the valve at its 25% open position. A simple equation to calculate the maximum balancing pressure for each valve can be read from Table 3. If the residual pressure exceeds a particular valve's maximum balancing pressure, it may be necessary to select 2 valves, and install them in series so that each one can remove half of the total pressure loss.
8. Having selected all of the valves, the selection information should be recorded in the form of a table cross-referenced to the relevant specification clauses and drawings. The information should include:
  - a. manufacturer's model and reference numbers;
  - b. valve sizes and kv or kvs values;
  - c. intended locations;
  - d. design flow rates;
  - e. anticipated pressure loss signals at design flow rates.

### 5.4 Software for selection

Manual sizing is certainly not very practical. There is calculation software available, such as CIMsize, that can size the valve quickly and effectively, thus reducing the chance of error.

The programs can also create useful reports for commissioning the system and the specifications with the number and type of valves required.



**Figure 57**  
CIMsize 1.0  
screenshot



# Balancing Valves Handbook

## Measuring flow rate

### 6. Measuring flow rate

In order to establish the flow rate through a fixed orifice double regulating valve it will be necessary to measure the pressure differential across the orifice. Having measured the pressure differential, and knowing the orifice kvs value, the flow rate can then be calculated using the following equation:

$$Q = \frac{kvs}{36} \cdot \sqrt{\Delta p}$$

where Q = flow rate in l/s, and  $\Delta P$  = pressure loss in kPa

Alternatively, for Cimberio valves, flow rate can be read directly from pressure loss versus flow rate graphs contained in the Commissioning Valve brochure.

Pressure differential can be measured using a manometer. The two most common types of manometer in use are the fluorocarbon/mercury manometer and the electronic digital manometer. The function and operation of the fluorocarbon/mercury manometer is described in the following section.

#### 6.1 Fluorocarbon/mercury manometer

The fluorocarbon or mercury manometer indicates pressure by the height of a column of fluorocarbon or mercury. The instrument is simple, has no moving parts, and regular calibration is not required. Provided certain basic procedures are followed, the instrument will give reliable and reproducible readings.

A good quality manometer will have the following features:

- a large fluid reservoir with means of zero adjustment; a safety chamber to reduce the risk of blowing the mercury out of the manometer if the installation pressure is greater than the range of the manometer; interchangeable connections for use on various pipe and flow measurement device tapings;
- sealable couplings to prevent loss of water from the manometer lines;
- a valve chamber for purging air out of the manometer and associated pipework;

- colour coded high and low pressure connecting lines (red/high pressure, blue/low pressure).

The following routine is used when setting up to take measurements with the fluorocarbon/mercury manometer:

- 1 Ensure that the manometer and hoses are suitable for the static pressure and temperature in the system. This is particularly important with differential pressure measurement. The differential may only be some 6 kPa but the pressure with respect to atmospheric on the manometer could be in excess of 500 kPa in a high rise building or pressurised high temperature hot water system;
- 2 Ensure that the manometer is of a suitable range to measure the anticipated maximum differential pressure;
- 3 Support the manometer firmly in a vertical position so that it cannot easily be dislodged;
- 4 Ensure that all the manometer chamber by-pass valves are securely closed;
- 5 Connect the appropriate couplings (binder probes) to the manometer lines;
- 6 Connect the manometer to the high pressure side of the flow measurement device;

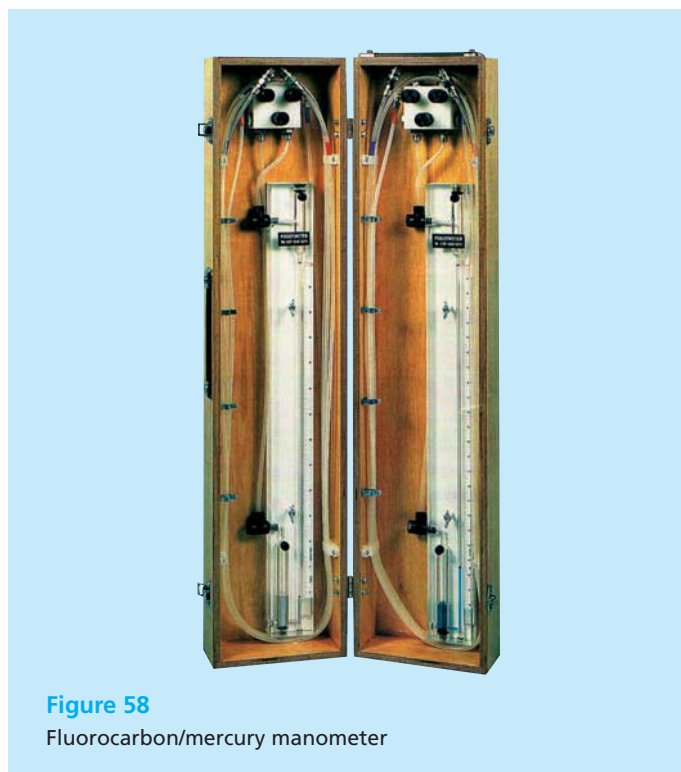


Figure 58

Fluorocarbon/mercury manometer



# Balancing Valves Handbook

## Measuring flow rate

7. Holding the low pressure manometer line over a bucket or drain, open the manometer by-pass valve;
8. Open the low pressure and high pressure chamber valves and allow water to flow through the connecting lines and into a bucket of water until all air bubbles are expelled;
9. Isolate the manometer lines from the flow device by closing the by-pass high pressure and low pressure valves. Connect the low pressure coupling to the low pressure test point, open its isolating valve and then reopen the by-pass valve. Zero the manometer by moving the scale against the meniscus.
10. Re-open the high pressure and low pressure valves;
11. Slowly close the by-pass valve, watching the fluorocarbon/mercury. When the valve is fully closed the differential pressure can be read;
12. To disconnect the manometer open the bypass valve, close the high pressure and low pressure chamber valves, re-close the bypass valve. Close the isolating valves on the pressure points, then carefully disconnect the manometer lines from the flow measurement device.

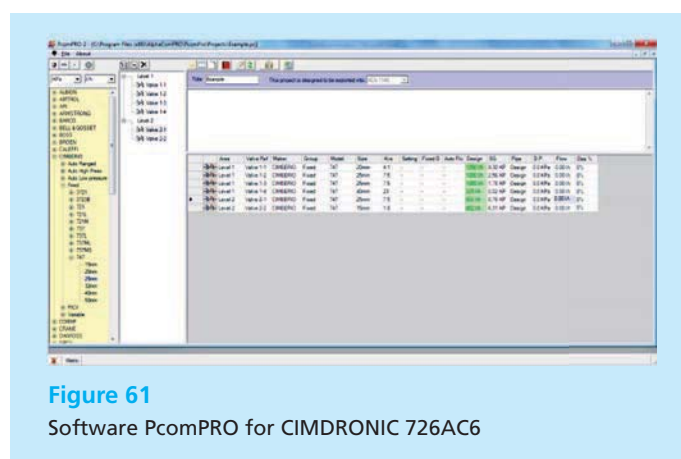


## 6.2 Digital manometer

Electronics have allowed measuring equipment to improve, reducing their volumes and weights. There are devices available that can measure both the differential pressure and calculate the flow rate circulating in the valve (by inserting the Kv value). There are also true Commissioning units that not only can measure pressure/flow rates, but systematically plan and perform the commissioning of the system.

These units have a large database with the available balancing valves and can easily perform the proportional balancing, storing all the measured flow rates for each valve in a report. These flow rates can be recalculated by the system designer in order to verify the calculation model used and, if necessary, intervene if there are any anomalies.

A useful software program is also available that schedules the commissioning, generating a report that provides all of the information in order to perform the correct balancing of each valve.





# Balancing Valves Handbook

## Flow regulation procedure

### 7. Flow regulation procedure

The on-site regulation of a water distribution system involves two basic processes:

1. The adjustment of branch regulating valves to obtain flow rates that are in correct ratio to each other. This is achieved by the technique of proportional balancing.
2. The adjustment of the total flow rate generated by the pump to obtain the design flow rate. This is achieved either by throttling down the pump regulating valve, by varying the pump speed, or by substituting the pump impeller, as appropriate, and as agreed with the design engineer.

#### 7.1 Fluorocarbon/mercury manometer

The technique of proportional balancing is accepted as the most appropriate method of effectively regulating distribution systems.

Consider a branch pipe (**Figure 59**) with several terminal units. The flow of water through each terminal represents a certain proportion or percentage of the total flow in the branch.

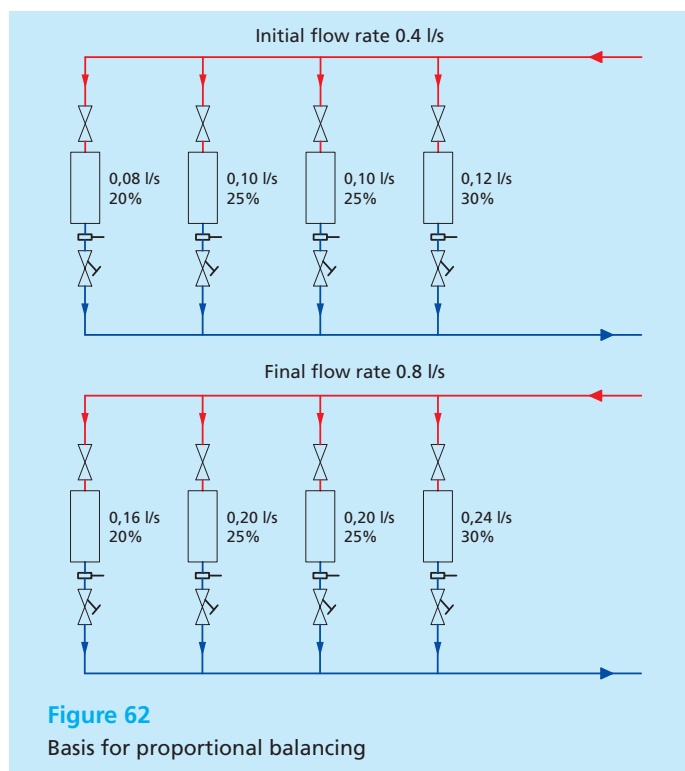


Figure 62

Basis for proportional balancing

Unless the terminal branch regulating valves are altered these proportions will remain the same, whatever the flow rate in the main pipe.

To balance one terminal unit against another, therefore, it is only necessary to adjust the regulating valves so that the terminal units share the flow in the correct proportions. It does not matter what the actual flow rate is at the time. When the main flow from the pump is regulated to its design flow rate, each terminal unit should also be passing its design flow, since each has been set to take its correct proportion.

#### 7.2 Index circuit

The index circuit is the circuit that, with the system in an unbalanced state, exhibits the greatest resistance to flow. It can be identified by calculation as the circuit with the highest pressure loss around it when design flow rates are assumed. On site it can be identified by flow measurement as the circuit for which the ratio of measured flow to design flow rate is lowest.

All systems have a single overall index circuit against which the pump pressure is calculated.

Furthermore, for any branch serving sub-branches, there will be an index sub-branch. Similarly each sub-branch may serve a number of terminal branches, one of which will be the index terminal branch.

If all branches are of equal resistance, the main system index circuit is likely to be from the pump to the most remote terminal, since this circuit has the longest pipe lengths. Similarly, sub-branch index circuits are likely to be from the start of the sub-branch to the most remote terminal they serve. However, if terminal branch resistances vary then the system index and branch indexes will not necessarily coincide with the most remote terminals. The location of each index will then depend on which circuit has the highest combination of pipe and terminal branch pressure losses.

As the circuit starting with the highest resistance, there is no need to regulate flow at an index. At the end of the balancing process, the index circuit should always have a fully open double regulating valve.





# Balancing Valves Handbook

## Flow regulation procedure

### 7.3 Proportional balancing procedure

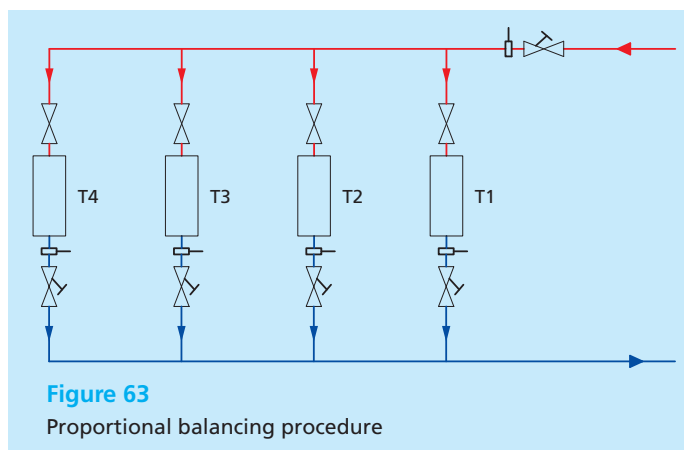


Figure 63  
Proportional balancing procedure

The balancing procedure must always start from the most remote branch and work back towards the nearest. Hence for the system shown in **Figure 60**, The flow rates to terminal branches T3, T2 and T1 would each be balanced in turn against the flow at the index, T4.

The balancing procedure is as follows:

1. Using the fixed orifice device at the main branch, measure the total flow entering the circuit. Ensure that this flow rate is between 110% and 120% of its design flow rate. It may be necessary to close down other branches to achieve this;
2. Using the fixed orifice device on each terminal, measure the flow rates through each terminal branch. For each terminal branch calculate the % design flow rate:  $\% \text{ design flow rate} = (\text{measured flow rate} / \text{design flow rate}) \times 100$ . If the signals at any of the flow measurement devices are below the measurement range of the device (i.e. less than 1kPa), further increase the total flow rate entering the branch by closing down adjacent branches;
3. Identify the index terminal branch. This will be the one with the lowest % design flow rate. Usually, but not always this will be the end branch (furthest from the pump). If the end branch is not the index, then close its regulating valve until its % design flow rate is approximately 10% less than that at the true index (so that the end branch becomes an artificial index). This needs to be done while simultaneously measuring the flow in the true index, since its flow will change as the end branch is adjusted;

4. Connect a manometer to the fixed orifice device in the end terminal branch. Working back towards the nearest branch, adjust each terminal branch regulating valve until its % design flow rate becomes equal to that at the end sub-branch. This needs to be done while simultaneously measuring the flow rate at the end sub-branch since its flow will change as upstream valves are adjusted;
5. Having achieved equal % design flow rates for each of the sub-branches, the sub-branch flow rates are now balanced. The balance cannot be disturbed by the adjustment of upstream valves. Hence, upstream branches can be balanced in exactly the same way;
6. Once the entire system has been balanced, adjust the flow from the pump to 110% of the total design flow rate for the system. All branches and sub-branches should now have flow rates close to their 100% design values.

### 7.4 Reporting

Having achieved an accurate balance of flow rates, each of the double regulating valves can be locked in position. For Cimberio regulating valves, this is achieved by opening the end cap to reveal an Allen key operated locking mechanism. By tightening the screw, the valve is locked in the set position so that the valve can be closed, but on re-opening the valve will not open beyond the locked position. Hence the flow balance is retained.

As a record for future system design checking, fault finding and maintenance, it is also essential that the original valve settings and measured flow rates are recorded in the form of a table.



# Balancing Valves Handbook

## Index of figures

### 8. Index of figures

<b>Figure 1</b>	Effects of flow variation	4
<b>Figure 2</b>	Effects of supply temperature	5
<b>Figure 3</b>	Effects of extra flows	6
<b>Figure 4</b>	Effects of flow variation in cooling systems	6
<b>Figure 5</b>	Constant volume system: 3-way diverting valve	8
<b>Figure 6</b>	Regulating of a 3-way diverting valve system	8
<b>Figure 7</b>	Variable volume system: 2-way control valve	8
<b>Figure 8</b>	Regulation of a 2-way control valve system	9
<b>Figure 9</b>	2-way control valve with regulating device	9
<b>Figure 10</b>	Example 1: small building	9
<b>Figure 11</b>	Example 1: unbalanced system	9
<b>Figure 12</b>	Example 1: balanced system	10
<b>Figure 13</b>	Example 1: traditional pump	10
<b>Figure 14</b>	Example 1: variable speed pump - constant head	10
<b>Figure 15</b>	Example 1: variable speed pump - proportional head	11
<b>Figure 16</b>	Example 2: layout	11
<b>Figure 17</b>	Example 2: unbalanced system	11
<b>Figure 18</b>	Example 2: balanced system	12
<b>Figure 19</b>	Example 2: Traditional pump	12
<b>Figure 20</b>	Example 2: variable speed pump - constant head	12
<b>Figure 21</b>	Example 2: Variable speed pump - proportional head	12
<b>Figure 22</b>	Double regulating valves	13
<b>Figure 23</b>	Regulating 2-way control valve with actuator	13
<b>Figure 24</b>	Installation	14
<b>Figure 25</b>	Fixed orifice flow measurement devices	14
<b>Figure 26</b>	Fixed orifice double regulating valves	15
<b>Figure 27</b>	Fixed orifice double regulating valves: pressures	15
<b>Figure 28</b>	Fixed orifice double regulating valves: velocities	15
<b>Figure 29</b>	Variable orifice double regulating valves	16
<b>Figure 30</b>	Variable orifice double regulating valves: pressures	16
<b>Figure 31</b>	Variable orifice double regulating valves: velocities	16
<b>Figure 32</b>	Impact of flow measurement accuracy on heating and cooling safety margins	17
<b>Figure 33</b>	Cartridge and section	18
<b>Figure 34</b>	CFR in constant volume systems	19
<b>Figure 35</b>	CFR in variable volume systems	19
<b>Figure 36</b>	CFR with actuator	19
<b>Figure 37</b>	Anti-condensation	19
<b>Figure 38</b>	CFR with heat exchanger	19
<b>Figure 39</b>	Water heating systems - Boilers	20
<b>Figure 40</b>	Water heating systems - Heat exchangers	20
<b>Figure 41</b>	Differential pressure control valve	20
<b>Figure 42</b>	Electronic differential pressure control valve	21
<b>Figure 43</b>	Differential pressure valve on the riser	21
<b>Figure 44</b>	Differential pressure valve on the manifold	21
<b>Figure 45</b>	Branch without DPCV	22
<b>Figure 46</b>	Authority	22
<b>Figure 47</b>	Branch with DPCV	22
<b>Figure 48</b>	Branch with EPCV	22
<b>Figure 49</b>	Pressure independent control system	23
<b>Figure 50</b>	Branch with PICV	23
<b>Figure 51</b>	PICV structure	23
<b>Figure 52</b>	Cimberio PICV	23
<b>Figure 53</b>	PICV layout	24
<b>Figure 54</b>	Flow rate vs Differential pressure	24
<b>Figure 55</b>	Reverse return layout for terminal branches	25
<b>Figure 56</b>	Residual Pressure	28
<b>Figure 57</b>	CIMsize 1.0 screenshot	29
<b>Figure 58</b>	Fluorocarbon/mercury manometer	30
<b>Figure 59</b>	Digital manometer CIMDRONIC 726DM10	31
<b>Figure 60</b>	Digital manometer CIMDRONIC 726	31
<b>Figure 61</b>	Software PcomPRO for CIMDRONIC 726AC6	31
<b>Figure 62</b>	Basis for proportional balancing	32
<b>Figure 63</b>	Proportional balancing procedure	33



# Balancing Valves Handbook

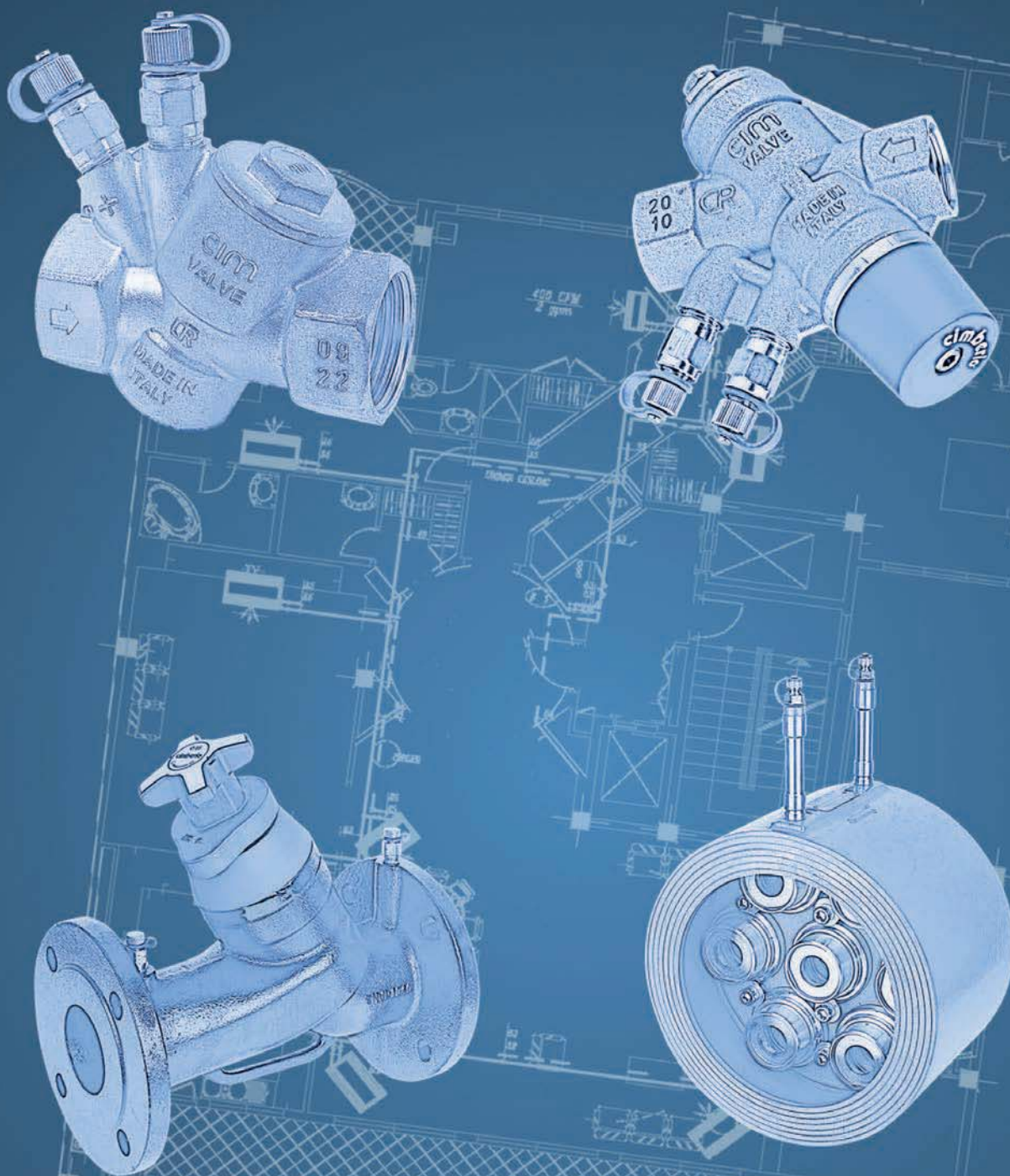
## Index of tables - Bibliography

### 9. Index of tables

<b>Table 1</b>	Common valve types and their functions	5
<b>Table 2</b>	Pumps technologies comparison	11
<b>Table 3</b>	Recommended range of water velocities	22
<b>Table 4</b>	Valve selection table DN15	25

### 10. Bibliography

- Commissioning Water Systems - BSRIA, BG 2/2010
- 2012 ASHRAE Handbook - HVAC Systems and Equipment
- 2011 ASHRAE Handbook - HVAC Applications
- Impianti termotecnici – prof. Giuliano Cammarata
- Le reti di distribuzione – Mario Doninelli
- I circuiti e i terminali degli impianti di climatizzazione - Mario Doninelli.



cav. uff. **GIACOMO CIMBERIO**  
s.p.a.

28017 San Maurizio d'Opaglio (NO) - Italy - Via Torchio, 57 - C.P. 106  
Tel. +39 0322 923001 - Fax: +39 0322 967216 / 967755  
skype: cimberiosk1, cimberiosk2  
info@cimberio.it

[www.cimberio.com](http://www.cimberio.com)