



# PRESSURE REDUCING VALVE

15MM - 50MM



AS 1357.2  
C OF C 040162



## *PRESSURE CONTROL IN COMMERCIAL AND HIGH RISE BUILDINGS*

### FUNCTION AND FEATURES

- |                                   |  |
|-----------------------------------|--|
| ■ Rated to 80°C                   | ■ Max 2,000kPa inlet pressure          |
| ■ Easily adjustable 100 - 600kPa  | ■ Gauge port standard (optional gauge) |
| ■ Exceptionally high flow rate    | ■ Inbuilt Strainer                     |
| ■ Dial-up adjustment              | ■ Replaceable cartridge                |
| ■ Union ends supplied as standard | ■ 'Low lead' brass alloy               |

## PRODUCT SPECIFICATIONS

Pressure reducing valves are a valuable asset to any piping system. Many people are under the misapprehension that more pressure is better when, in fact, it is often the reverse. Too much pressure in a system puts unnecessary strain on water heaters, plumbing joints, taps, washers, etc, increasing the chance of leaks, burst hoses on washing machines, etc, and adding greatly to water hammer problems.

The 535H has been developed specifically for use on the hot water supply in multi-storey high rise buildings in mind. The internal cartridge has been completely re-designed from the previous 535 series to allow better control at low flows, as well as exceptionally high maximum flow rates. The valve comes pre-set at 300kPa but is easily changed to your desired pressure setting by turning the adjustment knob on the top of the valve. Once the required pressure is 'dialed-up', the adjustment knob can be locked by tightening the screw located in the centre of the knob. A gauge port is standard on the body of the valve so that a gauge can be fitted to monitor the downstream pressure.

For ease of inspection and maintenance, a removable internal cartridge and strainer, containing all the regulating components, can be accessed through the top of the valve.

### TECHNICAL SPECIFICATIONS

PRESSURE RANGE	100 - 600kPa
FACTORY SET	300kPa
MAX. INLET PRESSURE	2,000kPa
MAX. TEMPERATURE	80°C
MEDIA	Water
OPTIONAL GAUGE - RANGE	0 - 1000kPa
GAUGE PORT SIZE	8mm

## SIZING A PRESSURE REDUCING VALVE

### WHAT IS THE CALCULATED FLOW REQUIREMENT MINIMUM & MAXIMUM?

Do not size only for a maximum flow requirement. During low flow demand, an oversized valve will operate in a nearly closed position causing premature wear and an undesirable noise may occur. If normal flow requires a line size PRV, a smaller PRV, piped parallel to the main PRV should be considered. Adjusting the smaller bypass PRV at 50-70kPa higher than the main PRV will ensure that the smaller bypass PRV will handle the lower flow demands and prevent premature wear and possible noise of the larger valve.

### SIZE FOR 1 - 2 M/S VELOCITY (SEE FLOW CHART BELOW)

With the nominal flow rate required, select a valve size that intersects the flow rate within 1-2 m/s on the water velocity chart. This range is advisable for good pressure control within the valve's optimum flow rate range. Sometimes there is a choice in terms of valve size within the acceptable water velocities; at that point you can decide if you want a better control at reduced flow rates with higher velocity and higher pressure loss at nominal flow rates (selecting the smaller size) or vice versa. The corresponding pressure loss graph may then be used at the same flow rate and valve size to obtain the pressure loss. If the minimum flow rate expected is less than around 0.3 m/s on the main PRV, then install a bypass line with a smaller valve where the minimum flow rate ideally falls within a velocity of 1-2 m/s of the valve.

### WHAT IS THE DESIRED REDUCED DOWNSTREAM PRESSURE?

Optimal performance is achieved at a 2:1 ratio, and a maximum of no more than 3:1. Example: 600kPa supply pressure, 300kPa static downstream pressure. 300kPa is the default factory setting. Where large pressure drops are required, for example in multi-storey buildings where inlet pressures are likely to exceed 1,000 kPa, this may be achieved through staged pressure reduction measures. A situation with low flow and a high differential pressure forces the valve to operate in a near closed position, potentially resulting in cavitation and possible noise.

## WATER VELOCITY CHART

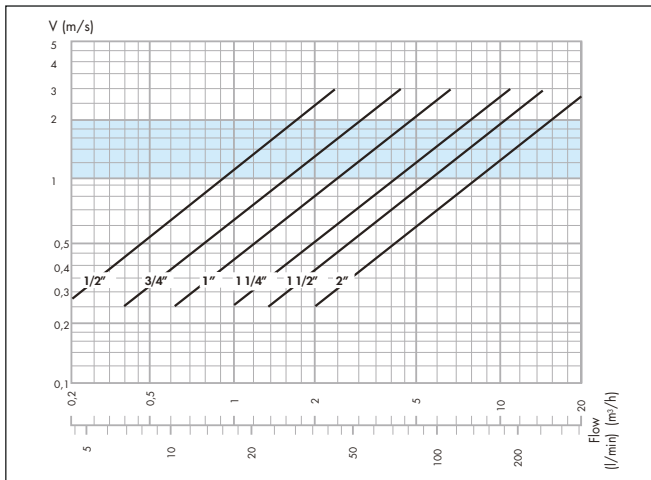

## PRESSURE LOSS CHART

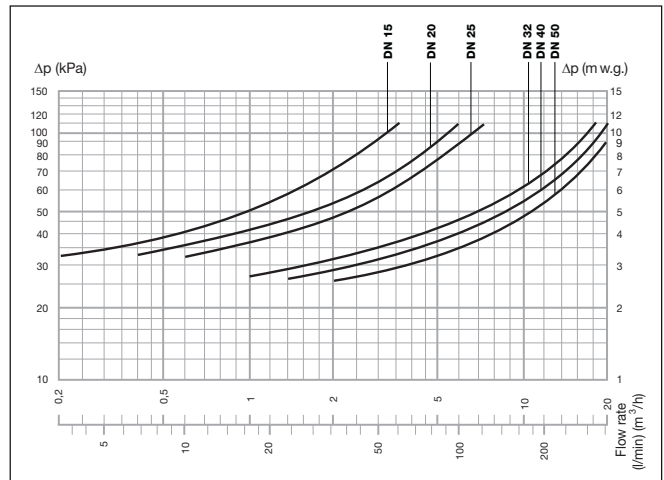

This chart shows curves at a 800kPa inlet pressure and 300kPa set pressure; curves for other settings are similar. The curve shifts slightly to the left for a smaller differential and to the right for a greater differential.

## DIAGRAM

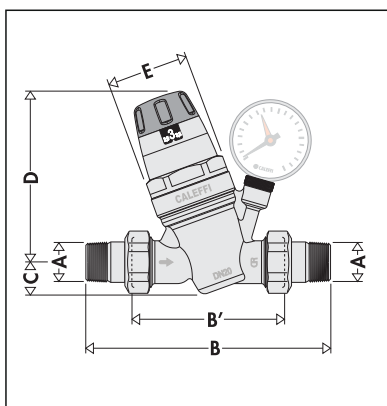

CODE	535040H	535050H	535060H	535070H	535080H	535090H
A	15mm	20mm	25mm	32mm	40mm	50mm
B	140	160	180	200	220	250
B'	76	90	95	110	120	130
C	20.5	20.5	20.5	40	40	40
D	112	112	112	178	178	178
E	Ø 54	Ø 54	Ø 54	Ø 73	Ø 73	Ø 73
Weight(kg)	0.92	1.06	1.38	2.6	3.4	4.3



040815-00