

## Thermostatic Mixing Valves for Solar Systems with OVERRIDE function

© Copyright 2016 Caleffi

### 2522TMF series

## Installation, commissioning and servicing instructions



### General

The Caleffi 2522TMF series is a high performance thermostatic mixing valve and has been specifically designed and manufactured to meet the requirements of:

**“AS 4032.1 Thermostatic Mixing Valves-Materials, Design and Performance requirements”.**

In certain sections of our society, there is a need to protect the most vulnerable from the danger of scalding caused by hot water. Hence, the need for thermostatic mixing valves.

The Caleffi 2522TMF series provides water at a safe and usable temperature in situation where the control of the temperature of the water discharging from an outlet is of the utmost importance, i.e. within hospitals, schools, nursing homes, etc.

This particular series of valves can be used with high temperature water in solar applications. The valve is designed to prevent the flow of water discharging from the mixed water outlet in the event of the failure of hot or cold supply.

The valve is complete with isolating valves, strainers and check valves at both hot and cold inlets, certified to AS 1357.1 and AS 1357.2.

The Caleffi 2522TMF series has an OVERRIDE function that allows to by pass the control of the temperature in order to perform the thermal disinfection against Legionella.

### Product Range

Item code 252212TMF: with isolating valves, strainers and check valves at the inlets. 15 mm (1/2") male, compression end connections for copper pipe, with OVERRIDE function.

Item code 252219TMF: with isolating valves, strainers and check valves at the inlets. 20 mm (3/4") male, compression end connections for copper pipe, with OVERRIDE function.

### Safety

The Caleffi 2522TMF series thermostatic mixing valve can give stable operation provided it is installed, commissioned and maintained as per the recommendation outlined in this manual. This valve cannot be considered as an alternative to adequate duty of care during its use and operation.

## Technical Data

Materials: - Valve body:	DZR alloy EN 12165 CW602N
- Regulating spindle:	DZR alloy EN 12164 CW602N
- Internal shutter:	PPO
- Sealing elements:	EPDM
- Cover:	ABS
- Isolating valve:	DZR alloy EN 12165 CW602N
- Strainer:	stainless steel

Medium: water

Temperature adjustment range: 30–50°C (55°C only under supervision and not within requirements of AS3500 and AS4032.1)

Factory pre-set temperature: 41°C

Set temperature: must be commissioned on site to achieve desired temperature

Temperature control:  $\pm 2^\circ\text{C}$

Minimum cold inlet temperature: 5°C

Maximum cold inlet temperature: 30°C

Minimum hot inlet temperature: 55°C

Maximum hot inlet temperature: 100°C

Maximum working pressure (static): 1400 kPa

Maximum working pressure (dynamic): 500 kPa

Minimum working pressure (dynamic): 20 kPa

Maximum unbalanced dynamic supply (hot/cold or cold/hot): 6 : 1

Minimum temperature differential between hot water inlet and mixed water outlet to ensure shut off function: 10°C

Minimum temperature differential between mixed water outlet and cold water inlet to ensure stable operation: 5°C

Minimum flow rate for stable operation: 4 l/min

## Dimensions

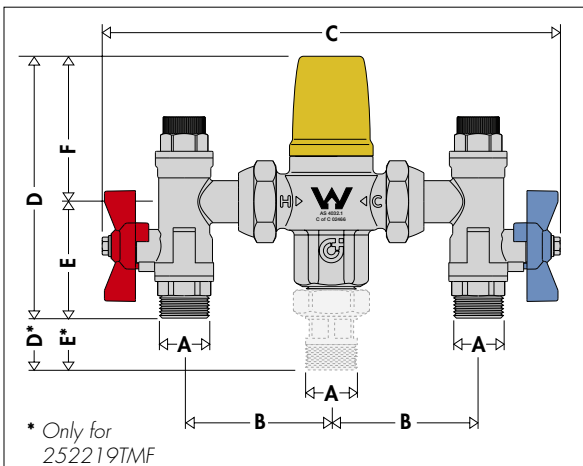

Code	252212TMF	252219TMF
A	1/2"	3/4"
B	62	76
C	198	237,5
D	115	144
E	55	84
F	60	60

## Operation

A thermostatic mixing valve mixes hot and cold water in such a way as to maintain the set temperature of the mixed water at the outlet.

A thermostatic element is fully immersed into the mixed water. It then contracts or expands causing movement of the piston, closing either the hot or cold inlets, regulating the flow rates entering the valve.

If there are variations of temperature or pressure at the inlets, the internal element automatically reacts attempting to restore the original temperature setting.

## Thermal shut off

In the event of a failure of a the hot or cold supply, the piston will shut off, stopping water discharging from the mixed water outlet.

The Caleffi valve requires a minimum temperature differential from hot inlet to mixed water outlet of 10°C to ensure the correct operation of the thermal shut off feature.

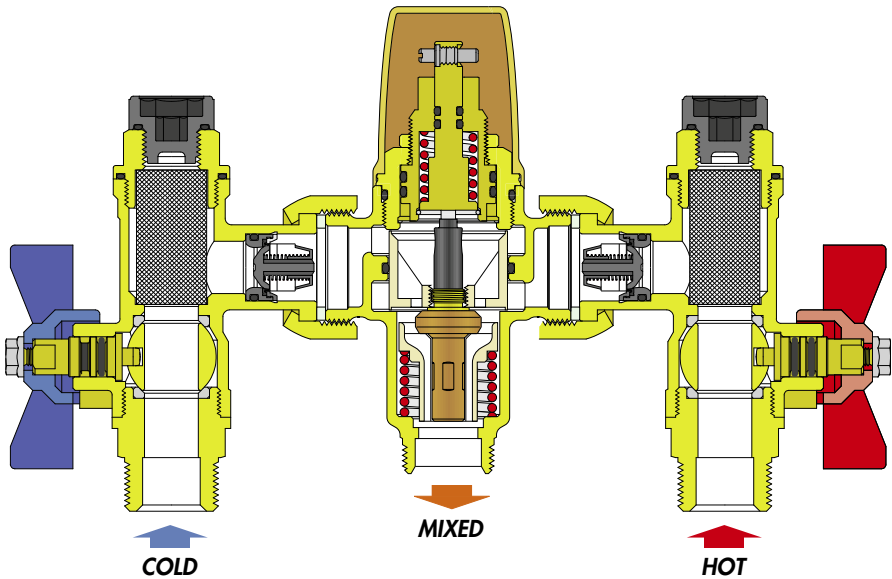

## OVERRIDE function

The OVERRIDE function allows to perform the thermal disinfection against Legionella using a special tool.

The special tool lifts the spindle in the up position by-passing the thermostatic cartridge operation.

The hot water from the network is thus delivered through the mix outlet port to the user.

## Flow rate graph

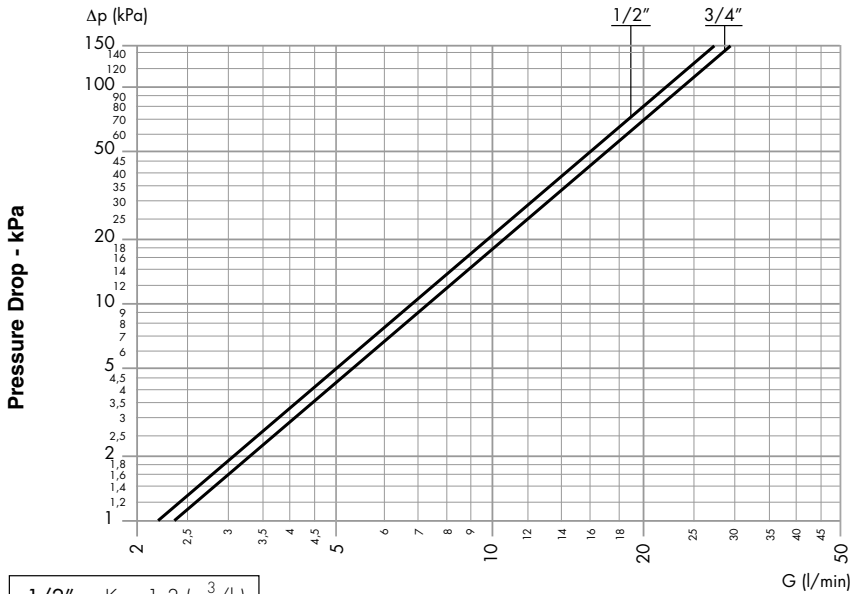

1/2"	$K_V = 1,3 \text{ (m}^3/\text{h)}$
3/4"	$K_V = 1,4 \text{ (m}^3/\text{h)}$

Flow rate graph - Litres per minute

## Flow rate

The Caleffi 2522TMF series is a thermostatic mixing valve suitable for a point of use application or for a limited number of outlets.

The system must be sized taking into account the current legislation with regard to the nominal flow rate of each outlet. The reference is AS/NZS 3500.1.

## Exploded diagram

- 1 PROTECTIVE CAP
- 2 TEMPERATURE SPINDLE LOCKING NUT
- 3 UPPER BODY
- 4 'O' RING SEAL
- 4<sub>a</sub> 'O' RING SEAL
- 5 THERMOSTATIC ELEMENT
- 6 FLOW CONVEYOR
- 7 UNDER SPRING
- 8 VALVE BODY
- 9 SEAL
- 10 INSERT CHECK VALVE
- 11 UNION NUT
- 12 ISOLATING VALVE
- 13 INSERT STRAINER
- 14 SPECIAL TOOL

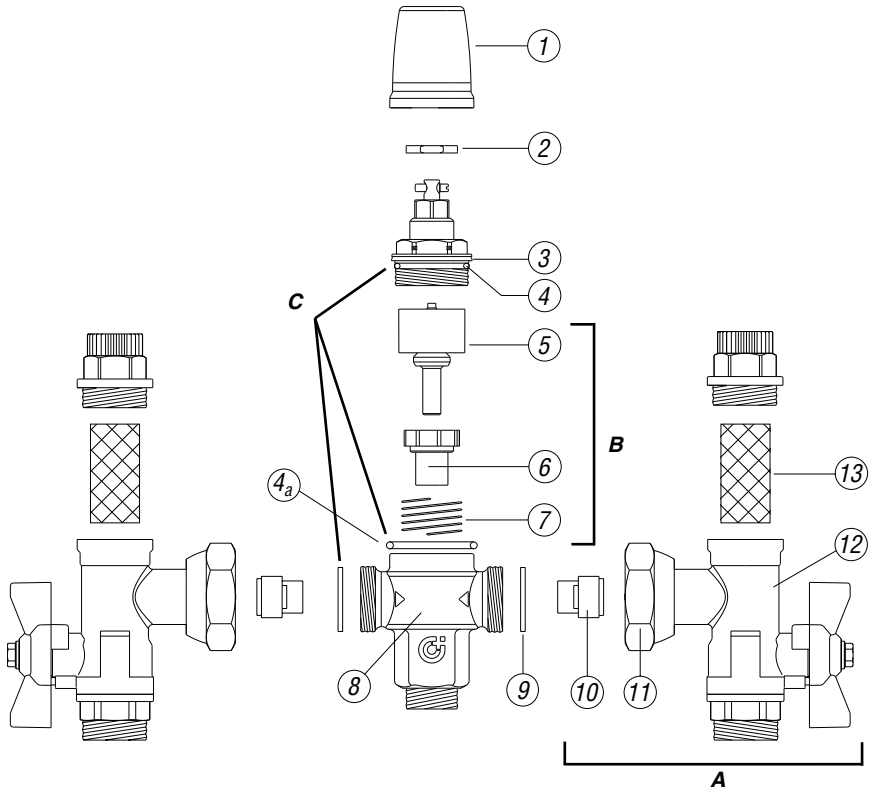
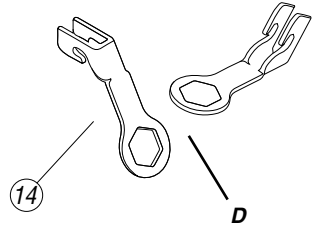

## Installation

The Caleffi 2522TMF series must be installed by a licensed plumber or, where applicable, a licenced plumber who has undertaken T.A.F.E. training in Thermostatic Mixing Valves. The installer has a duty of care to ensure that all aspects of the installation comply with AS/NZS 3500 current regulations and legislation. The Caleffi 2522TMF series should be installed using the appropriate Standard, Code of Practice and legislation applicable to each state and following the details in this manual.

Prior to the installation of the Caleffi 2522TMF series valve the system must be checked to ensure that the **system operating conditions fall within the recommended operating range of the valve, i.e. verify supply temperatures, supply pressures, risk assessments, etc.**

The supply system into which the Caleffi 2522TMF series is to be installed must be thoroughly flushed and cleaned to remove any debris which may accumulate during the installation. Failure to remove any debris will affect the performance and the manufacturer's warranty on the product. In areas that are subject to high levels of aggressive water, provision must be made to treat the water prior to it entering the valve.

System flushing, cleaning and disinfection of the pipework to which the valve is installed shall be performed by suitably qualified persons in accordance with the system component manufacturer's instructions, AS/NZS 3500 along with any other applicable local authority requirements. Exceeding the maximum stated chemical concentrations and/or duration of exposure may negatively impact on the performance of the system and/or components installed such as the pressure reducing valve. Chemical dosed products must be chemically compatible with materials used for the construction of the thermostatic mixing valve, specified in its technical documentation.

The valve can be installed in any position, whether vertical or horizontal. It is essential that the access to the valve is not obstructed for future maintenance that may be required to the valve or associated fittings.

It is essential that when the installation is designed and/or installed, all current legislation is noted, e.g. the maximum distance from the outlet of the valve to any terminal fitting. We recommend that the Caleffi 2522TMF series valve is installed as close as practically possible to the outlet/s which it is serving.

The connecting hot and cold water supplies must be connected to the valve strictly in accordance with the indications on the body of the valve. The inlets of the valves are clearly marked with the letters H (hot) and C (cold). The outlet is marked with the word MIX.

Where one or both the incoming supply pressures are excessive, a Caleffi pressure reducing valve should be fitted to reduce the pressure(s) to within the limits as quoted previously.

Any thermostatic mixing valve must be installed with isolating valves, line strainers and check valves at both the inlets. Isolating valves are required so that the water supply to the valve can be isolated in the event that servicing is required. Strainers are required to prevent debris from entering the valve. Check valves are required to both hot and cold inlets to prevent cross-connection.

The Caleffi 2522TMF series is supplied complete with the isolating valves, line strainers and the check valves at the hot and cold inlets.

To ensure that the performance of the Caleffi 2522TMF series valve is maintained (in the event of cold water failure), the temperature of the hot water supply at the point of entry to the valve must be a minimum of 10°C higher than the set mixed water discharge temperature.

The pipework to and from the valve must not be used to support the weight of the valve.

If the valve is not installed correctly then it will not function correctly and may put the user in danger.

## Installation diagram

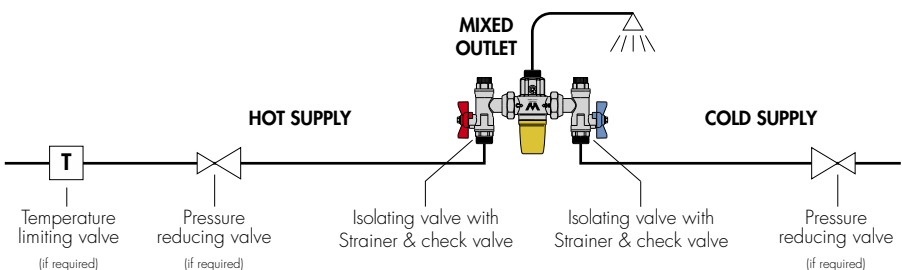

## Applications

The Caleffi 2522TMF series thermostatic mixing valve is suitable for point-of-use application and multiple outlet applications in systems where hot water is stored and delivered to outlets at very high temperature.

The Caleffi 2522TMF series provides water at a safe and usable temperature in a situation where the control of the temperature of the water discharging from an outlet is of the utmost importance i.e. within hospitals, schools, nursing homes, etc.

**This type of valve is intended mainly for use in applications with set temperature below 45°C.**

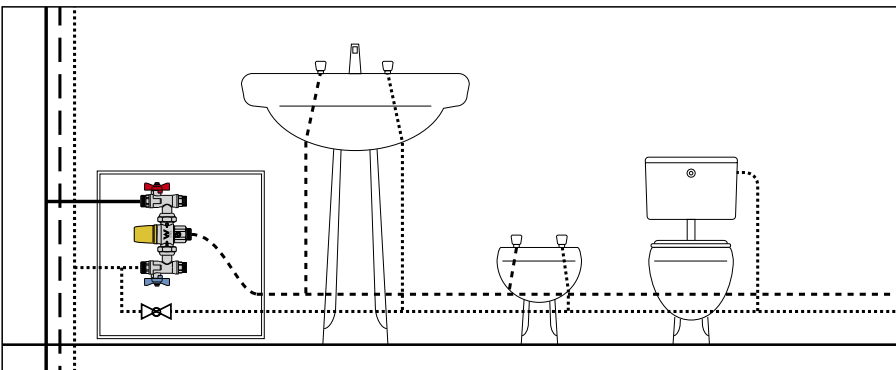
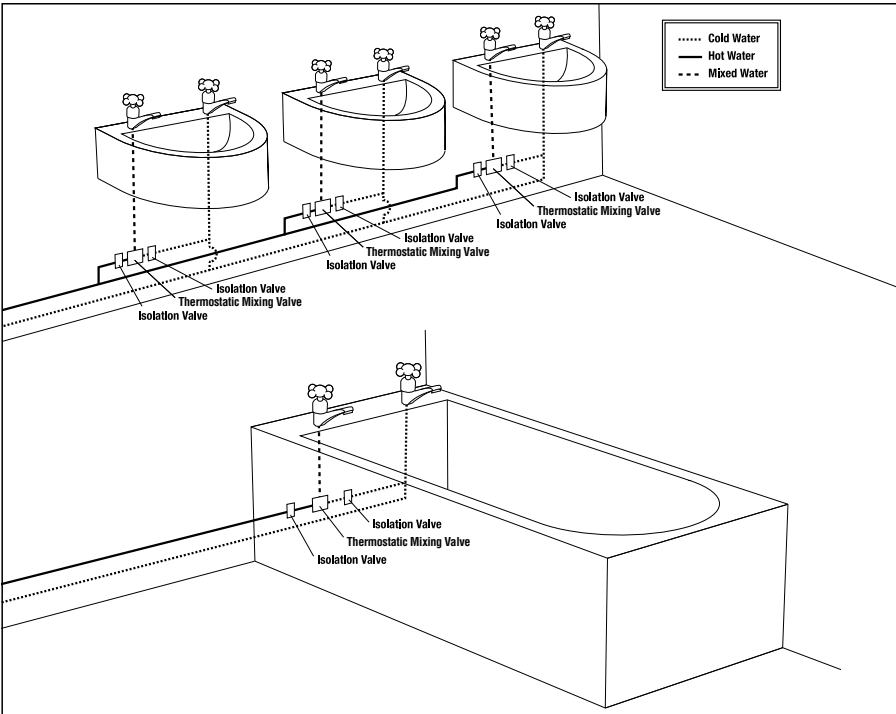

## Commissioning

Upon completion of the installation, the valve should be tested and commissioned in accordance with AS 4032.3 as per the procedure outlined below or as specified by the local authority.

The following instructions should be read and understood prior to commissioning the Caleffi 2522TMF series valve. If, under any circumstances, there are aspects of the installation/system which do not comply with our requirements or the specifications as laid down, the valve must not be put into service until the installation/system does comply.

- 1) Ensure that the system is thoroughly clean and free from debris prior to commissioning the thermostatic mixing valve.
- 2) We recommend that the commissioning of temperatures are carried out using a suitably calibrated and accurate digital thermometer.  
The valve is commissioned by measuring the mixed water temperature at the outlet.
- 3) In accordance with the requirements of AS/NZS 3500, all new water installations shall deliver hot water at the outlet of the sanitary fixtures used primarily for personal hygiene purposes at a temperature not exceeding: 45°C for general Health applications; 43.5°C advisable for childhood centres, primary and secondary schools and nursing homes or similar facilities for aged, sick or disabled persons and 50°C in all other classes of buildings.
- 4) The temperature at the outlet of each valve must be set taking into consideration any fluctuations which may occur within the system due to simultaneous demand.
- 5) Once the supply temperatures are stabilised and the normal operating conditions are established, the valve can be commissioned. The temperature setting can be adjusted by removing the cap from the valve body and using the special tool onto the temperature adjustment spindle. We suggest that the following sequence is followed when commissioning the valve.
  - a) Set the mixed water discharge temperature to the required temperature.
  - b) Measure and record the temperature of hot and cold water supplies at the connections to the valve.
  - c) Measure and record the temperature of the water discharging from the largest and smallest volume draw off points.
  - d) Perform the thermal shut-off test. Isolate the cold water supply to the Caleffi valve and monitor the mixed water temperature. The outlet flow should quickly cease flowing.
  - e) Measure and record the maximum mixed water temperature. The temperature should not exceed that allowed by the applicable standard or code of practice for each state. temperature after the mixed water temperature has stabilised. The final temperature found during this test should not exceed the permitted values +2°C.
- 6) Once the desired temperature has been reached, the adjustment spindle can be locked in position using the locking nut supplied with the valve.
- 7) Once the desired temperature is established, place again the cap on to the valve into its original position to prevent tampering by unauthorised persons.

We recommend that the above information is recorded in the Commissioning Report and updated on the Service Report when any work is carried out on the valve.



## Temperature adjustment

Remove the cap

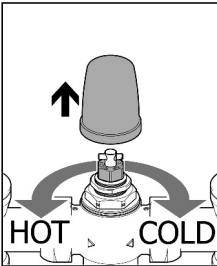

Use of special tool for temperature adjustment

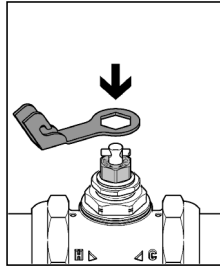

Temperature adjustment

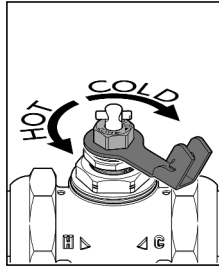

Lock adjustment spindle with locking nut

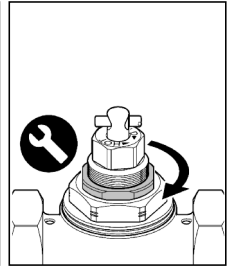

## OVERRIDE operation

- 1) Close hot and cold water inlet isolating valves (**A-B**).
- 2) Remove the top cover.
- 3) Using the special tool, lift the spindle in the up position, leaving the tool in place
- 3a)** After fully screwing the locking nut, it's possible to rotate the spindle in the optimal position by using the special tool.
- 4) Open the hot water isolating valve (**A**) and open a dwelling point like a tap (**C**).
- 5) Perform the thermal flush with hot water on all taps in the system.
- 6) Close the hot water inlet (**A**) and any dwelling point (**C**).
- 7) Put the spindle back to its original position, removing the tool.
- 8) The valve mixed water set temperature remains at the value that was set commissioned.
- 9) Open the hot and cold water isolating valve (**A-B**).
- 10) The TMV is now back to its normal working condition.

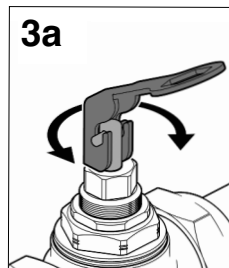
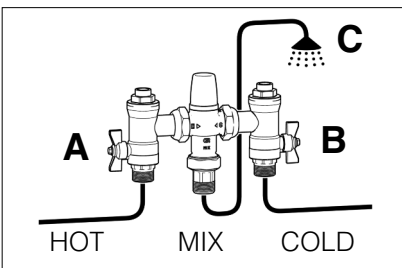

## **Maintenance**

In-service tests should be carried out regularly to monitor and record the performance of the valve in accordance with AS 4032.3. Deterioration in performance can indicate the need for servicing of the valve and/or water supply. If, during these tests, the mixed water temperature has changed significantly from the previous test results, record the change before re-adjusting the mixed water temperature. If the final mixed water temperature is greater than the permitted values, we recommend that the details quoted in Installation and Commissioning sections are verified and that service work is required.

We recommend that at least every 12 months, or more frequently if the need arises, that the following aspects are checked to ensure that the optimum performance level of the valve is maintained.

With reference to the exploded diagram:

- 1) On the Caleffi 2522TMF series valves, the inlet filters (13) on both the hot and cold water supplies can be removed for cleaning by unscrewing the top plug.
- 2) The built-in check valves (10) on the Caleffi 2522TMF series valves can be accessed in a similar way to 1) to ensure freedom of operation and correct seating.
- 3) In case of service work, the internal components of the valve can be disassembled for cleaning and descaling.
  - a) Remove the cap of the valve (1) and the locking nut (2)
  - b) Remove the upper body (3) using a suitable spanner
  - c) Remove parts 5-7 noting the correct orientation
  - d) Remove all signs of scale and dirt from the internal part using a suitable descaling solution.
  - e) Lubricate the o-rings with an approved grease and re-assemble all the components.

Once the serviceable items have been dealt with, we recommend that the commissioning details as stated previously are repeated ensuring that a suitably accurate thermometer is used.

Should the valve still not function correctly, it may be necessary to replace the thermal element or other components. Refer to spare part kits and contact our Agents for details and advice.

For best performance we recommend that all o-rings are lubricated regularly and the thermostat is replaced every 5 years.

## **Spare parts**

With reference to the exploded diagram, the following spare parts are available on request for Caleffi 2522TMF series valves:

- Kit A - Service Kit for the inlet sub-assembly.
- Kit B - Service Kit for the internal components.
- Kit C - Replacement o-rings and seals.
- Kit D - Special tool.

## Fault finding

Under normal operating conditions, the Caleffi 2522TMF series thermostatic mixing valve will provide a very high level of performance. However, in some circumstances, where our maintenance plan is not followed, the following problems may arise.

<b>Symptom</b>	<b>Cause</b>	<b>Corrective action</b>
Hot water at the cold taps	a) Operation of the insert check valve is hindered; check valve is not sealing correctly. b) Check valves not fitted.	<ul style="list-style-type: none"> <li>• Replace faulty check valves</li> </ul>
Fluctuating mixed water temperature	a) Erratic supply temperatures at the inlets of the valve. b) Starvation of the water supplies at the inlets of the valve. c) Incorrect commissioning of the valve.	<ul style="list-style-type: none"> <li>• Restore inlet conditions within the limits of the valve.</li> </ul>
Erratic flow of water from the valve	a) Insufficient water supplies. b) Fluctuations in supply pressures/temperatures. c) Adverse effect created by other draw off points on the system.	<ul style="list-style-type: none"> <li>• Stabilise inlet supply conditions.</li> </ul>
No flow of water from the valve	a) In-line filters blocked. b) Insufficient supply pressures. c) Debris obstructing valve operation.	<ul style="list-style-type: none"> <li>• Clean filters.</li> <li>• Restore inlet supplies.</li> <li>• Clean debris or scale from valve.</li> </ul>
Valve does not fail safe when tested	a) Installation not in accordance with our recommendations. b) The minimum temperature differential not achieved. c) Internal mechanism hindered by debris.	<ul style="list-style-type: none"> <li>• Install as outlined in the instructions.</li> <li>• Raise hot water temperature.</li> <li>• Clean debris or scale from valve.</li> </ul>

---

## **Supplementary notes to: Installation, commissioning and servicing instructions**

---

**The following supplementary notes must be read in conjunction with the installation, commissioning and servicing instructions, code H0001498, for the Caleffi thermostatic mixing valves 2522TMF series.**

### **Product Range**

Item code 252212TMF: with isolating valves, strainers and check valves at the inlets. 15 mm (1/2") male, compression end connections for copper pipe with OVERRIDE function.

Item code 252219TMF: with isolating valves, strainers and check valves at the inlets. 20 mm (3/4") male, compression end connections for copper pipe with OVERRIDE function.

### **Approvals**

#### **SAI global approval**

The Caleffi 2522TMF series thermostatic mixing valves are approved by SAI Global as satisfying to the requirements of AS 4032.1 : 2005 and it has the Licence N° 2466 and 25724.

#### **NSW approval**

The Caleffi 2522TMF series thermostatic mixing valves are approved by the relevant authorities for use in health care buildings.

This product must be installed and commissioned in accordance with the manufacturer's instructions, with the requirements of the local Water Supply Authority and with the documents following:

- 1) "Hosplan Code of Practice for Thermostatic mixing valves", 1990
- 2) Rule NSW 5.22 of the NSW Code of Practice "Plumbing and Drainage", 1999
- 3) NSW Department "Code of Practice for the Control of Legionnaires' Disease", 1991
- 4) AS 4032.1 2005 and AS 4032.3:2005 Australian Standard for Thermostatic Mixing Valves
- 5) Regulation under Nursing Homes Act 1998 and Private Hospitals and Day Procedure Centres Act 1988

## 1) Special conditions Applicable to Patient Occupied Areas of Health Care Buildings in NSW

Recommended Hot Water Range: 63°C to 73°C  
See **I)** Clause 1.6.1 of AS 3500.4.2.  
**II)** Clause 74 of NSW Public Health Regulation-1991

Maximum hot inlet temperature: 100°C  
Minimum hot inlet temperature: 55°C  
Minimum cold inlet temperature: 5°C

Maximum working pressure (static): 1400 kPa  
Maximum working pressure (dynamic): 500 kPa  
Minimum working pressure (dynamic): 10 kPa

Maximum unbalanced dynamic supply (hot/cold or cold/hot): 6:1

Minimum temperature differential between hot water inlet and mixed water outlet to ensure fail safe function: 10°C

Minimum flow rate for stable operation: 4 l/min

- 2) If the valve is to be used for temperatures and pressures outside the above limits, please consult the Australian Agent.
- 3) If the cold water temperature is near freezing point, refer to AS 3500.1.2.
- 4) Temperature setting measured at outlet fixtures as required in Patient Occupied Areas of Health Care Buildings in NSW:

Adults: 40.5°C to 45°C **Safety cut off 46.0°C in case of Cold Water Failure**

Children and neonates: 38°C to 40.5°C **Safety cut off 43.5°C in case of Cold Water Failure**

### Applications

- 1) The Caleffi 2522TMF series are suitable for use with either mains pressure or gravity feed potable water supplies.
- 2) The system design, installation, commissioning and servicing must comply with the requirements specified in AS/NZS 3666, SAA/SNZ H332 and local legislation.
- 3) The installation, commissioning and servicing instructions, code H0001498, is packed with each valve.

## **Operating Limits**

- I) For the manufacturer's limits in terms of flow rates, pressures and temperature, refer to the manual code H0001498.
- II) For optimum performance, dynamic supply pressures should be nominally balanced to within 10% of the lowest inlet pressure. Avoid draw-offs from hot water or cold water outlets immediately before the inlets of the thermostatic mixing valves as they can create an imbalance in the dynamic inlet pressures.
  - a) When necessary, utilise a pressure reducing valve on the common cold water inlet to the heater and to the cold inlet to the mixing valve to equalise the hot and cold water pressures. AS 3500.1.2 recommends maximum static pressure of 500 kPa.
  - b) When necessary, utilise adjustable pressure reducing valve on the hot and cold water inlets to the mixing valve to equalise the inlet pressures. When dynamic pressures are unequal, the minimum flow rate must be such that the pressure ratio does not exceed 6:1.
  - c) Any pressure reducing valve to be used with hot water should be suitable for use with hot water at the maximum operating temperature.

## **Pressure ratio**

This pressure ratio is calculated as:

Hot dynamic inlet pressure/Cold dynamic inlet pressure or  
Cold dynamic inlet pressure/Hot dynamic inlet pressure

The maximum dynamic pressure ratio is 6:1

Pressure ratios outside the maximum allowed must be avoided because the ability of the valve to control the mixed temperature within tolerance will be affected. If the requirements of the Hosplan Code of Practice for Thermostatic mixing valves are met (balanced pressures within 10% of the lowest value), then the working conditions of the valve are within 6:1 pressure ratio.

## **Installation and servicing special notes**

- I) These service instructions must be read in conjunction with the manual code H0001498
- II) Allow a minimum of 70 mm clearance above the temperature adjustment spindle to enable removal of the internal regulating components
- III) For typical installation diagram, refer to page 108 figure N°4 "Hosplan Code of Practice for Thermostatic mixing valves".
- IV) For special conditions regarding Health care installation in hospitals and nursing homes, refer to "Hosplan Code of Practice for Thermostatic mixing valves".
- V) For the preparation of commissioning report, refer to appendix 2 and 3 of "Hosplan Code of Practice for Thermostatic mixing valves".

## COMMISSIONING REPORT FOR CALEFFI THERMOSTATIC MIXING VALVE INSTALLED IN HEALTH CARE BUILDINGS

Use a separate sheet for each valve

### Location

Name of Establishment:.....  
 Address of Establishment:.....  
 Contact Person:..... Tel:..... Date:.....  
 Work order No:.....

### Installation conditions

Make and Model of hot water unit:.....  
 Temp of Hot Water.....°C, Pressure.....kPa  
 Cold water supply via..... Pressure reducing valve fitted: YES/NO  
 Temperature of Cold Water..... °C, Pressure.....kPa

Make of mixing valve..... Model No..... Size.....

Valve Location/building:.....

Valve Identification No:.....

Total No of mixing valves on Site/Building:.....

No of Outlets Served by this valve: Baths ( ), Basins ( ), Showers ( )

Other Outlets-Details:.....

Valve installed to requirements of:

- |                                     |        |
|-------------------------------------|--------|
| a) The drawing and specification    | YES/NO |
| b) The valve manufacturer/supplier  | YES/NO |
| c) The HOSPLAN code for TMV         | YES/NO |
| d) The local water supply authority | YES/NO |

If NO, give details and action taken.....

### Test Results (complete the attached table)

Valve considered satisfactory for use: YES/NO

If NO, state reason and action taken.....

It is hereby certified that all the commissioning work has been carried out by the undersigned in accordance with the requirements of the HOSPLAN Code of Practice for thermostatic mixing valves.

Valve initial service due:..... (Max 6 months use)

Valve commissioned by:.....

Signature of Licensed Plumber:..... Licence/Cert. No.....

Business name of plumbing contractor:.....

Contractor's authority No:..... Date:.....

NOTE

**A duplicate copy of this report is to be retained at the site for any inspection by authorised persons e.g. Department of Health**

**The following information is to be provided by site manager/owner:**

Valve size and installation recommended by (Name):.....  
 Valve supplied by (Name):.....  
 Valve installed by (Name):.....  
 Date of Installation:.....Drawing No:.....  
 Certificate of Compliance/Inspection No:.....Dated:.....  
 Service Manual on Site: YES/NO  
 Report Received by (Name):.....  
 Position:.....  
 Signature:..... Date:.....

For and on behalf of the health establishment

**Test Results**

Valve Location/Building:.....  
 Room or Area Designation:.....  
 Work Order No:.....

Warm Water Outlet Fixture No.	*Name/Type/Size & Location of Outlet Fixture (Bath, Shower, Basin, Other)	Flow rate of Design Warm Water (l/sec)		Temp. of Warm Water (°C)	
		One Outlet in use	**All req'd Outlets in use	One Outlet in use	**All req'd Outlets in use

\*Give details of brand and model designation  
 \*\*Commensurate with the design flowrate for the mixing valve (see drawing)  
 NOTE: An accurate digital type thermometer is necessary for the temperature measurements.  
 Prescribed temperature range for warm water.....°C to .....°C  
 Fail safe at both minimum and maximum design flow rates (Passed/Failed)  
 Signature of Licensed Plumber:.....Licence/Cert. No.....  
 Business Name of Plumbing Contractor:.....  
 Contractor's Authority No..... Date:.....



**SERVICE REPORT FOR  
CALEFFI THERMOSTATIC MIXING VALVE  
INSTALLED IN HEALTH CARE BUILDINGS**

Use a separate sheet for each valve

**Location**

Name of Establishment:.....

Address of Establishment:.....

Contact Person:.....Tel:.....Date:.....

Work order No:.....

**Installation conditions**

Make and Model of hot water unit:.....

Make of mixing valve.....Model No.....Size.....

Valve Location/building:.....

Valve Identification No:.....

Total No of mixing valves on Site/Building:.....

No of Outlets Served by this valve: Baths ( ), Basins ( ), Showers ( )

Other Outlets-Details:.....

Valve installed to requirements of:

e) The drawing and specification YES/NO

f) The valve manufacturer/supplier YES/NO

g) The HOSPLAN code for TMV YES/NO

h) The local water supply authority YES/NO

If NO, give details and action taken.....

.....

.....

Any current complaints concerning installation or operation reported by establishment personnel or stated in previous report:

If YES, give details.....

.....

Particulars of service work carried out during this visit.....

.....

List of items replaced (and part numbers) during this visit.....

.....

Temp. of warm water at outlet.....°C, Fail Safe Test: PASSED/FAILED

Valve considered satisfactory for further use: YES/NO.....

If NO, reason and action taken:.....

.....

Date next service due:.....(12 months maximum)

It is hereby certified that all service work has been carried out by the undersigned in accordance with the requirements of the HOSPLAN Code of Practice for thermostatic mixing valves.

Name of Licensed Plumber (Print):.....

Signature:.....Licence/Certificate No:.....

Business Name of Plumbing Contractor:.....

Contractor's Authority No:.....Date of Service:.....

**NOTE**

***A duplicate copy of this report is to be retained at the site for any inspection by authorised persons e.g. Department of Health***

**The following information is to be provided by site manager/owner:**

Valve size and installation recommended by (Name):.....

Valve supplied by (Name):.....

Valve installed by (Name):.....

Date of Installation:.....Drawing No:.....

Certificate of Compliance/Inspection No:.....Dated:.....

Service Manual on Site: YES/NO

Date of Previous Service:.....

Previous Service Carried Out by:.....

Current Report Received by (Name).....

Position:.....

Signature:.....Date:.....

For and on behalf of the health establishment



***AUSTRALIAN AGENT***

**All Valve Industries**

**Unit 2, 18-28 Sir Joseph Banks Drive  
Kurnell NSW 2231**

**Ph: (02) 8543 9811**

**Fax: (02) 8543 9822**

**Email: [info@allvalve.com.au](mailto:info@allvalve.com.au)**

**CALEFFI**

---

S.S. 229 · Km 26,5 · I-28010 Fontaneto d'Agogna (NO) · Tel. Int. +39 322 8491 R.A. · Fax +39 322 863723

[Http://www.caleffi.com](http://www.caleffi.com) · [E-mail:info@caleffi.it](mailto:info@caleffi.it)