

FLANGED GAS BALL VALVE

25MM - 200MM



AGA APPROVED FLANGED ISOLATION VALVE

FUNCTION AND FEATURES

- | | |
|---------------------------------------|---------------------------------|
| ■ European Design and Manufactured | ■ Full Bore Design |
| ■ Gas Approval; AGA 7517 (32mm-200mm) | ■ Underground Key Cap Available |
| ■ Sturdy Ductile Iron Construction | ■ ISO 5211 Mounting Pad |

PRODUCT SPECIFICATIONS

PERFORMANCE

WORKING TEMPERATURE	-20 - 60°C
MAX WORKING PRESSURE	1,600kPa
FLANGE CONNECTION	Table 'E' *
AGA APPROVAL	Licence 7517

* ANSI or DIN sizes available upon request

* 150mm size is drilled Table 'D' due to size / location of bolts on flange

MATERIALS

1	BODY	DUCTILE IRON - GGG40
2	BALL	304SS
3	STEM	420SS
4	SEATS	PTFE
5	O-RING	VITON
6	HANDLE	IRON - ST 37-2

DIAGRAM

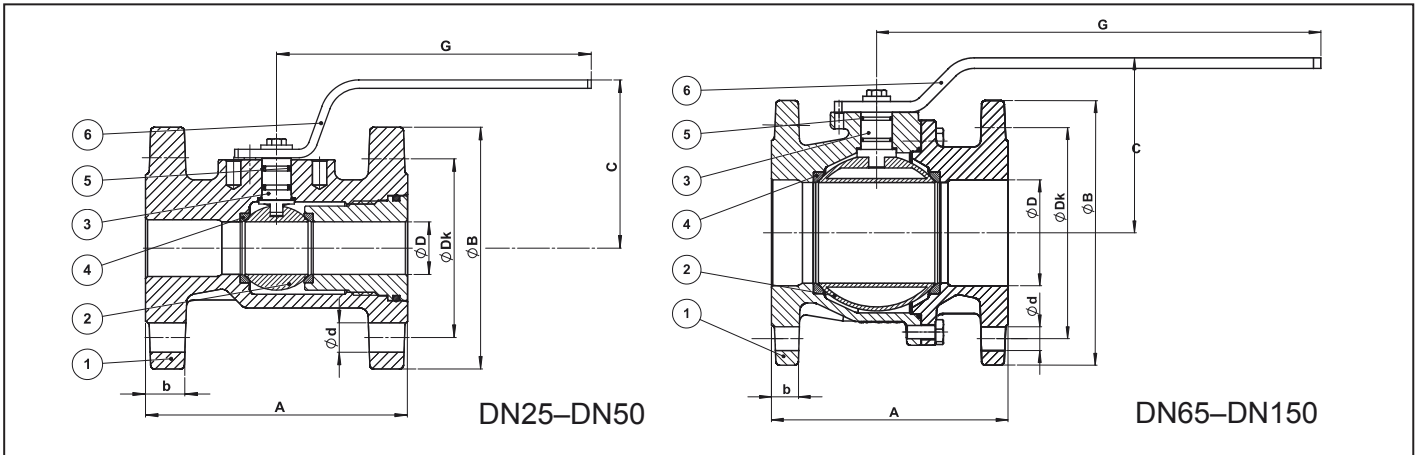

CODE	SIZE	A	ØB	C	ØD	G	B	ØDK	ØD	NR.	FLANGE ISO	WEIGHT (KG)
GBVFE-025	25	125	115	76	25	150	18	85	14	4	F03	3.5
GBVFE-032	32	130	140	92	31	235	18	100	18	4	F04	5.3
GBVFE-040	40	140	150	97	39	235	18	110	18	4	F05	6.6
GBVFE-050	50	150	165	105	49	271	20	125	18	4	F05	8.8
GBVFE-065	65	170	185	124	63	288	18	145	18	4	F07	11.4
GBVFE-080	80	180	200	133	76	288	20	160	18	8	F07	14.0
GBVFE-100	100	190	220	153	100	288	20	180	18	8	F07	17.0
GBVFE-150	150	210	285	203	150	541	22	240	22	8	F10	37.0
GBVFE-200	200	400	340	316	200	1000	24	295	22	12	F12	84.0

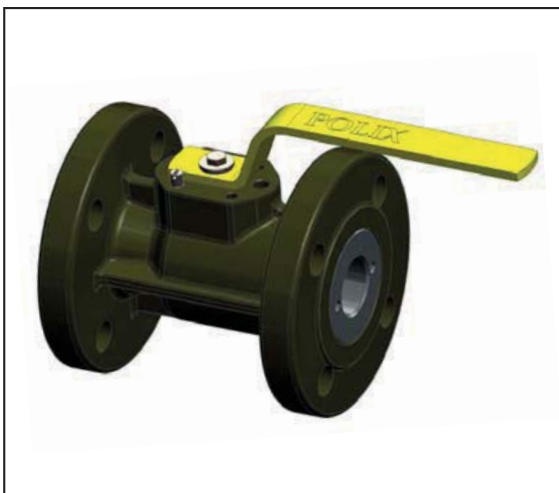

VALVE OPTIONS

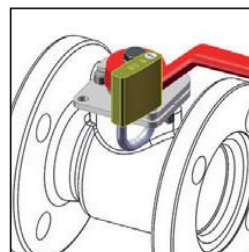

Key Lockers

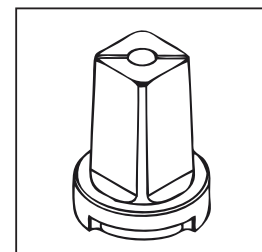

Underground adaptor



201020-01