



**Section VIII
Pressure Vessels**

10-322 and 10-512 Series OEM Style Steam Safety Relief Valves

National Board capacity-certified safety valves; brass body with optional satin or polished chrome finish. Protects against excess pressure from thermal expansion and steam caused by failure of Btu input controls.

ASME Section VIII
 Sizes 1/2" and 3/4"
 Set pressures 15 to 60 psig @ 312°F max
 National Board Certified Capacity

Applications: Ideally suited for OEM applications such as steam carpet and jewelry cleaners, autoclaves, sterilizers, commercial pressure cookers, steam jacketed kettles, dental equipment, coffee makers and similar equipment.

Features

- Stainless steel springs
- Small physical size
- Discharge capacities to 725 lbs./hr.
- Soft seating for exceptional seat tightness
- Pressure settings 15 to 60 psig
- 10-322 in polished chrome only
- CRN OG8547.5C, registered in all Canadian provinces and territories

Options: (Model 10-512 Only)

- Rough or polished chrome finish
- Stainless steel wetted trim
- BSP pipe connections



10-512



10-322

Dimensions and Weights

Model Number	Size (in./mm.)		Set Pressure Range psig	Height (in./mm.)	Wt./100 (lbs./kg.)
	Inlet NPT	Outlet NPT			
10-322	3/4 M	3/4 F	20-60	3.75	128
	20	20			
10-512	1/2 M	1/2 F	15-60	2.62	58
	15	15			

P/N Suffix Key

Set Pressure psig	*Certified Capacities				
	Plain Brass	Satin Chrome	Polished Chrome	10-322 lbs./hr. kg./hr.	10-512 lbs./hr. kg./hr.
15	-01	-J2	-65	-	151 68.5
20	-02	-41	-67	325 147.4	178 80.7
25	-04	-43	-69	375 170.1	205 92.9
30	-05	-44	-70	425 192.7	232 105.2
35	-06	-45	-71	475 215.4	258 117.0
40	-07	-46	-72	525 238.1	285 129.3
45	-09	-48	-74	575 260.8	312 141.5
50	-10	-49	-75	625 283.5	339 153.7
55	-11	-50	-76	675 306.1	366 166.0
60	-12	-51	-77	725 328.8	392 177.8

* ASME (UV) Rating - 90% of actual capacity at 10% accumulation. Capacity in lbs. of saturated steam per hour.

ORDERING CODE:

Use two-digit suffix number to indicate set pressure and body finish.

EXAMPLE:

10-322-67 = 3/4" 10-322 set @ 20 psig, polished chrome finish.

NOTE:

- Model 10-322 available in polished chrome finish only.
- Valves may be set for any pressure between 15 and 60 psig. Consult factory for pressure settings not shown.

10-322 and 10-512 Series OEM Style Steam Safety Relief Valves

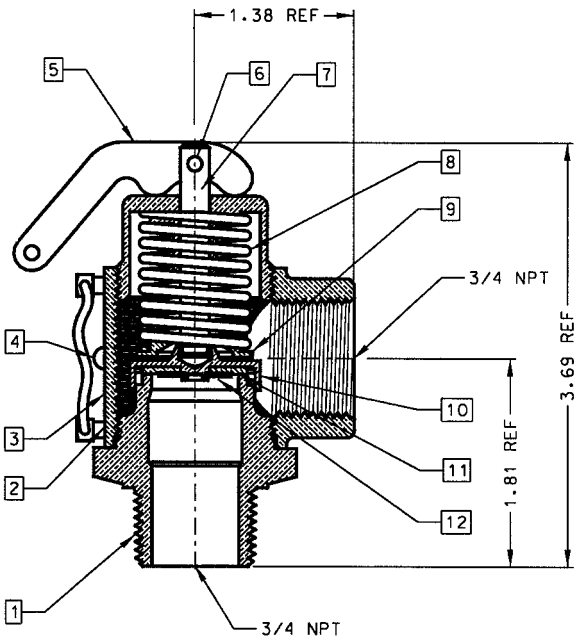

10-322 Materials

Item	Component	Material
1	NOZZLE	BRASS ASTM B-16
2	BODY	BRASS ASTM B-16
3	NAMEPLATE	ALUMINUM
4	DRIVE SCREW	STEEL, ZINC PLATED
5	HANDLE	STEEL, ZINC PLATED
6	COTTER PIN	STEEL, ZINC PLATED
7	STEM	BRASS ASTM B-16
8	SPRING	STAINLESS STEEL
9	SPR. WASHER	BRASS ASTM B-16
10	DISC	BRASS ASTM B-16
11	SEAT	TEFLON FACED EPDM
12	WASHER	BRASS ASTM B-16

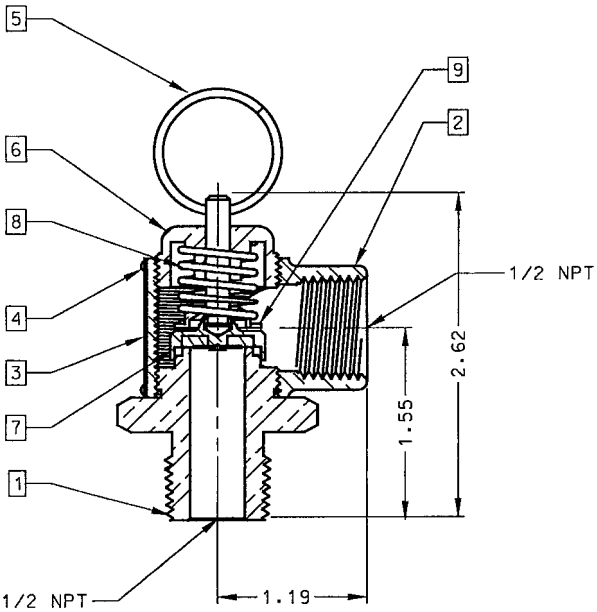

10-512 Materials

Item	Component	Material
1	NOZZLE	BRASS ASTM B-16
2	BODY	BRASS ASTM B-16
3	NAMEPLATE	ALUMINUM
4	DRIVE SCREW	STEEL, ZINC PLATED
5	PULL RING	STEEL, ZINC PLATED
6	CAP	BRASS ASTM B-16
7	DISC ASSEMBLY	BRASS, SILICONE
8	SPRING	STAINLESS STEEL
9	SPR. WASHER	BRASS ASTM B-16

Model 10-512 available with optional stainless steel wetted trim. Nozzle, disc holder and disc washer are type 316 stainless steel.