

Tempering valve

5213 series

Installation, commissioning and servicing instructions



The tempering valve is used to regulate the set temperature of mixed hot and cold water even when variations occur in the water supply conditions.

The Caleffi 5213 series has been specifically designed and manufactured to meet the requirements of “**AS 4032.2:2002 Tempering valves and end-of-line temperature actuated devices**”.



Australian
Standard

AS4032.2 LIC.2466
Standards Australia

Product Code

521312: 15 mm (1/2")

521319: 20 mm (3/4")

Valves are supplied with in-line strainers and check valves plus union at the inlets.

The end connections are male compression.

Technical Data

Materials: - Valve body:	DZR alloy UNI EN 12165 CW602N
- Regulating spindle:	DZR alloy UNI EN 12165 CW602N
- Internal shutter:	PPO
- Sealing elements:	EPDM
- Cap:	ABS
Temperature adjustment range:	30÷50°C
Temperature set:	Must be commissioned on site to achieve desired temperature
Temperature control:	±3°C
Minimum cold inlet temperature:	5°C
Maximum cold inlet temperature:	30°C
Minimum hot inlet temperature:	55°C
Maximum hot inlet temperature:	85°C
Maximum working pressure (static):	1400 kPa
Maximum working pressure (dynamic):	500 kPa
Minimum working pressure (dynamic):	20 kPa
Maximum unbalanced dynamic supply (hot/cold or cold/hot):	6:1
Minimum temperature differential between hot water inlet and mixed water outlet to ensure thermal shutoff function:	10°C
Minimum temperature differential between mixed water outlet and cold water inlet to ensure stable operation:	5°C
Minimum flow rate for stable operation:	4 l/min

Dimensions

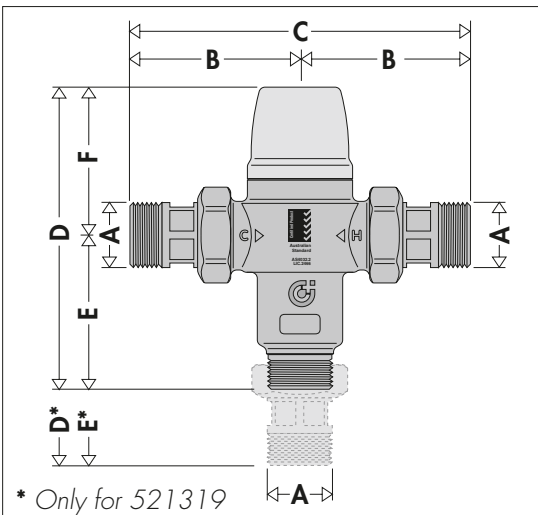

Code	521312	521319
A	Ø 15	Ø 20
B	62,5	69
C	125	138
D	97,5	133
E	48,5	84
F	49	49

Operation

A tempering valve mixes hot and cold water in such a way as to maintain the set temperature of the mixed water at the outlet.

A thermostatic element is fully immersed into the mixed water. It then contracts or expands causing movement of the piston, closing either the hot or cold inlets, thus regulating the flow of water entering the valve.

If there are variations of temperature or pressure at the inlets, the internal element automatically reacts attempting to restore the original temperature setting.

Thermal shutoff

In the event of a failure of the hot or cold supply, the piston will shut off, stopping water discharging from the mixed water outlet.

The Caleffi valve requires a minimum temperature differential from hot inlet to mixed water outlet of 10°C to ensure the correct operation of the thermal shutoff feature.

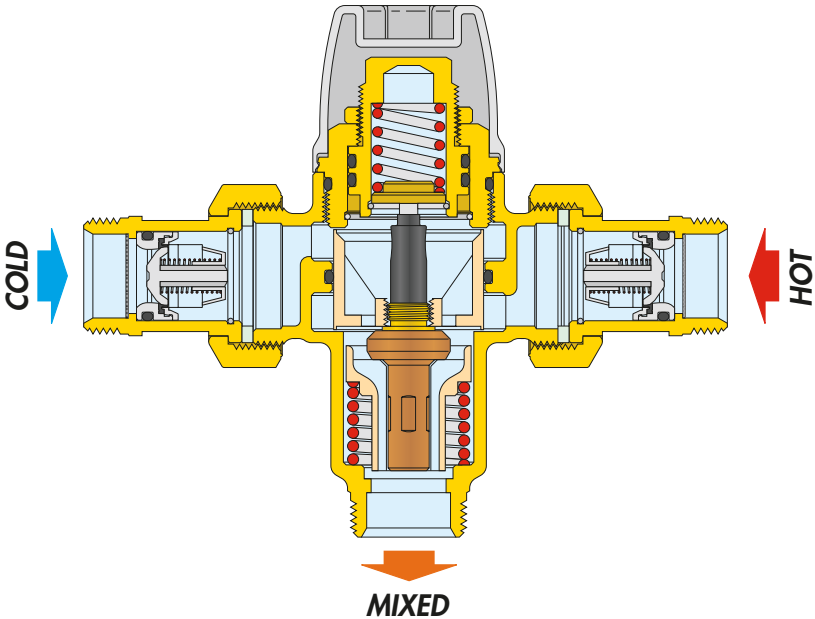

Flow rate graph

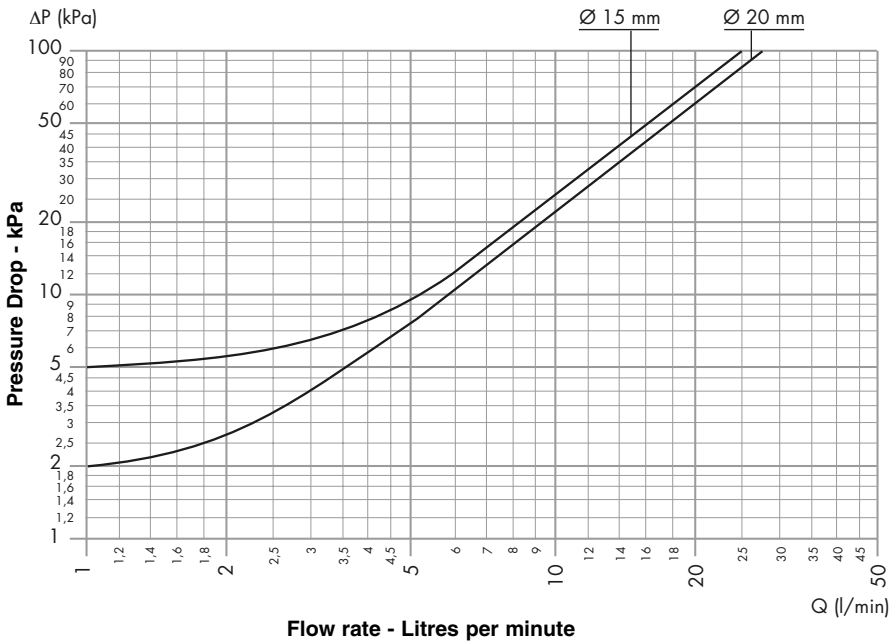

Code	Ø (mm)	Kv (m ³ /h)
521312	15	1,5
521319	20	1,7

Flow rate

Caleffi series 5213 tempering valves are designed to be typically installed at the hot water storage heater. In order to ensure a set temperature, the tempering valve must have a minimum flow rate of 4 l/min.

The system must be sized taking into account the current legislation with regard to the nominal flow rate of each outlet.

The reference is AS/NZS 3500.1 Table 3.1.

Exploded diagram

- 1 CAP
- 2 LOCKING NUT
- 3 TEMPERATURE ADJUSTMENT SPINDLE
- 4 VALVE BODY
- 5 GASKET
- 6 UNION NUT
- 7 INSERT CHECK VALVE
- 8 INSERT STRAINER
- 9 TAIL PIECE BODY

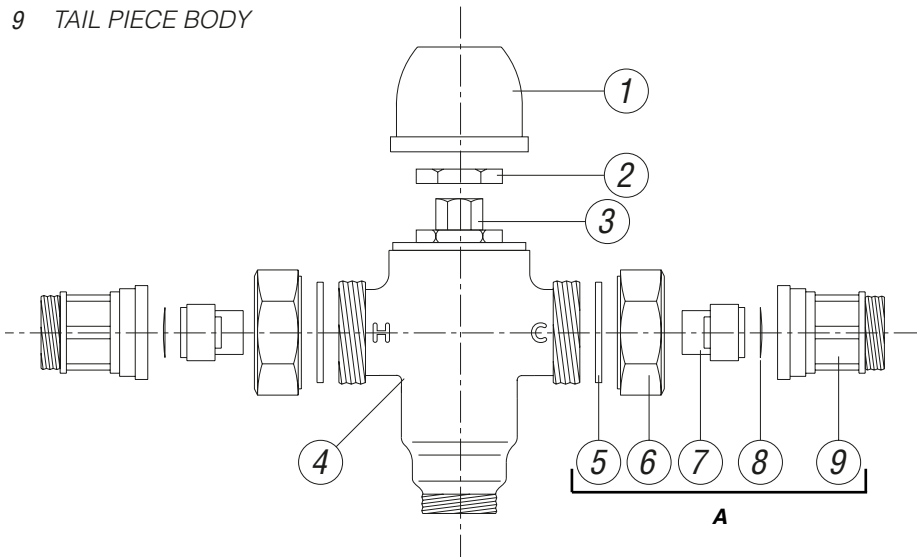

Installation

The Caleffi 5213 must be installed by a licensed plumber. The installer has a duty of care to ensure that all aspects of the installation comply with the AS/NZS 3500, appropriate Codes of Practice, local regulations and following these instructions.

Prior to the installation of the Caleffi 5213 series valve, the system must be checked to ensure that the **system operating conditions fall within the recommended operating range of the valve, i.e. verify supply temperatures, supply pressures, risk assessments, etc.**

The supply system into which the Caleffi 5213 series is to be installed must be thoroughly flushed and cleaned to remove any debris which may accumulate during the installation. Failure to remove any debris will affect the performance and the manufacturer's warranty on the product.

In areas that are subject to high levels of aggressive water, provision must be made to treat the water prior to it entering the valve.

The valve can be installed in any position, whether vertical or horizontal. To allow for maintenance, it is essential that access to the valve and fittings is not impeded.

It is essential that when the installation is designed and/or installed, all current legislation is noted, e.g. the maximum distance from the outlet of the valve to any terminal fitting.

The connecting hot and cold water supplies must be connected to the valve strictly in accordance with the indications on the body of the valve.

The inlets of the valves are clearly marked with the letter H (Hot) and C (Cold).

The outlet is marked with the word MIX.

Where one or both the incoming supply pressures are excessive, a Caleffi pressure reducing valve should be fitted to reduce the pressure(s) to within the limits as quoted previously.

Any tempering valve must be installed with isolating valves, line strainers and check valves at both the inlets. Isolating valves are required so that the water supply to the valve can be isolated in the event that servicing is required. Strainers are required to prevent debris from entering the valve. Check valves are required at both hot and cold inlets to prevent cross-connection.

The Caleffi 5213 series is supplied complete with line strainers and check valves at the hot and cold inlets.

Isolation valves must be fitted at the inlets.

The temperature of the hot water at the inlet must be 10°C higher than the set mixed water outlet to ensure the Caleffi 5213 series thermal shutoff function.

The pipework must not be used to support the weight of the valve.

If the valve is not installed correctly then it will not function correctly and may put the user in danger.

Installation diagram

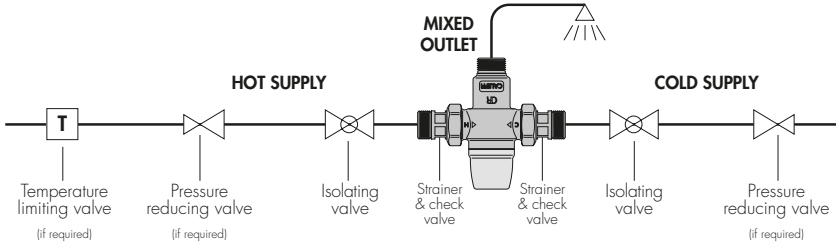

Application diagrams

System without recirculation

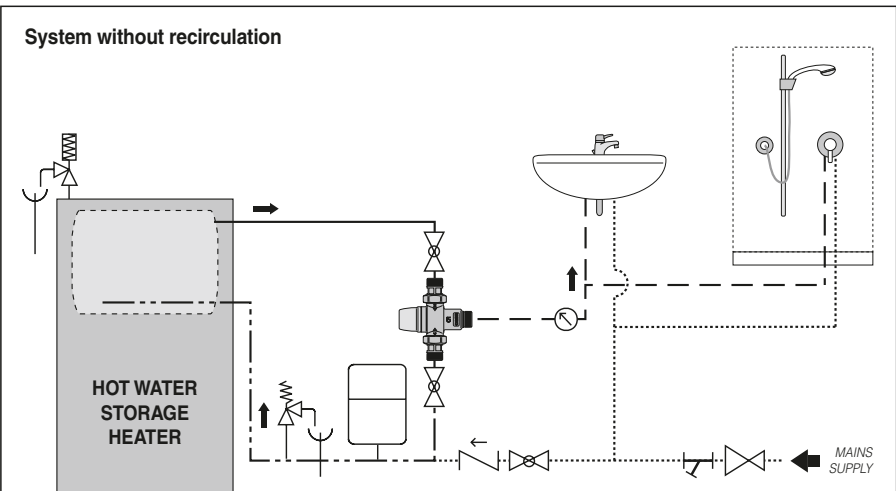

System with recirculation

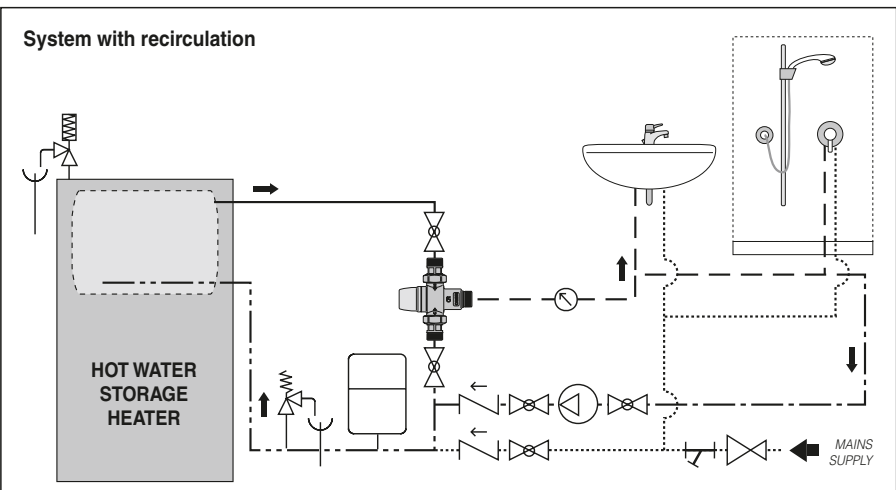

Commissioning

Upon completion of the installation, the valve should be tested and commissioned as per the procedure outlined below or as specified by the local authority.

The following instructions should be read and understood prior to commissioning the Caleffi 5213 series valve. If, under any circumstances, there are aspects of the installation/system which do not comply with our requirements or the specifications as laid down, the valve must not be put into service until the installation/system does comply.

- 1) Ensure that the system is thoroughly clean and free from debris prior to commissioning the thermostatic mixing valve.
- 2) We recommend that the commissioning of temperatures are carried out using a suitably calibrated and accurate digital thermometer.
The valve is commissioned by measuring the mixed water temperature at the outlet.
- 3) The temperature of the mixed water supplied to an outlet primarily for personal hygiene purposes shall be in accordance with the requirements of AS/NZS 3500.
- 4) The temperature at the outlet of each valve must be set taking into consideration any fluctuations which may occur within the system due to simultaneous demand.
- 5) Once the supply temperatures are stabilised and the normal operating conditions are established, the valve can be commissioned. Due to the unique design of the cap, the temperature setting can be adjusted by removing the cap from the valve body and reversing the cap onto the temperature adjustment spindle. We suggest that the following sequence is followed when commissioning the valve.
 - a) Set the mixed water discharge temperature to the required temperature.
 - b) Measure and record the temperature of hot and cold water supplies at the connections to the valve.
 - c) Measure and record the temperature of the water discharging from the largest and smallest volume draw off points.
 - d) Perform the thermal shut-off test. Isolate the cold water supply to the Caleffi valve and monitor the mixed water temperature. The outlet flow should quickly cease.
 - e) Measure and record the maximum mixed water temperature. The temperature should not exceed that allowed by the applicable standard or code of practice for each state.
 - f) Restore the cold water supply to the valve and measure and record the outlet temperature after the mixed water temperature has stabilised. The final temperature found during this test should not exceed the permitted values +3°C.
- 6) Once the desired temperature has been reached, the temperature adjustment spindle can be locked in position using the locking nut supplied.
- 7) Once the desired temperature is established, remove the cap from the temperature adjustment spindle and secure the cap back on to the valve to prevent tampering by unauthorised persons.

We recommend that the above information is recorded in a Commissioning Report and updated on a Service Report when any work is carried out on the valve.

Temperature adjustment

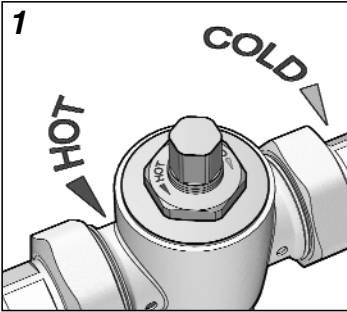

◀ Direction of temperature adjustment

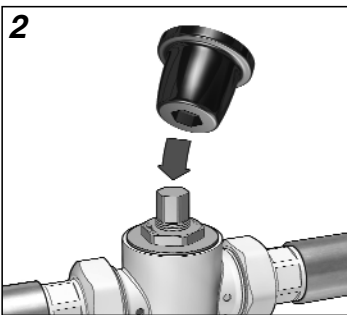

◀ Fitting cap for temperature adjustment

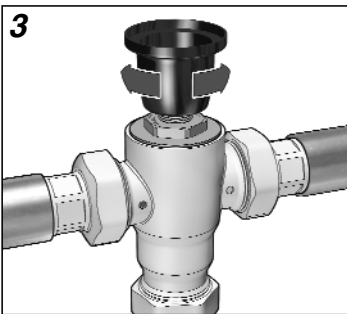

◀ Temperature adjustment cap in place

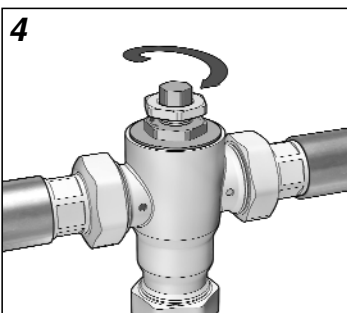

◀ Lock temperature adjustment spindle with locking nut

Maintenance

Tests should be carried out periodically to monitor the performance of the valve. Deterioration in performance can indicate the need for varying water supply conditions and/or maintenance or replacement of the valve. If, during these tests, the mixed water temperature has changed significantly from the previous test results, record the change before re-adjusting the mixed water temperature. If the final mixed water temperature is greater than the permitted values, we recommend that the details quoted in Installation and Commissioning sections are verified and that service work is required.

We recommend that the following checks are carried out at least every 12 months, or more frequently if required, to ensure that the optimum performance of the valve is maintained.

With reference to the exploded diagram:

- 1) On the Caleffi 5213 series valves, the inlet strainers (8) on both hot and cold water inlets can be removed for cleaning by unscrewing the inlet union nuts and carefully pulling apart the connecting pipework.
- 2) The built-in check valves (7) on the Caleffi 5213 series valves can be accessed in a similar way to 1) to ensure freedom of operation and correct seating.
- 3) Limescale can be removed by immersion in a suitable de-scaling fluid.
- 4) The valve body must not be disassembled.

When this maintenance is complete, we recommend that the commissioning process is repeated.

Should the valve still not function correctly, it may be necessary to replace it.

We recommend that, as a safety measure, the Caleffi 5213 series is replaced after 5 years service. Contact Agent Service Department for details and advice.

Spare parts

The following spare parts for the Caleffi 5213 are available upon request.

Kit A - Service kit for the inlet sub-assembly. Refer to the exploded diagram.

Fault finding

Under normal operating conditions the Caleffi 5213 series tempering valve will provide a very high level of performance. However, in some circumstances, where our maintenance plan is not followed, the following problems may arise.

Symptom	Cause	Corrective action
Hot water at the cold taps	a) Operation of the insert check valve is hindered; check valve is not sealing correctly. b) Check valves not fitted.	<ul style="list-style-type: none"> • Replace faulty check valves
Fluctuating mixed water temperature	a) Erratic supply temperatures at the inlets of the valve. b) Starvation of the water supplies at the inlets of the valve. c) Incorrect commissioning of the valve.	<ul style="list-style-type: none"> • Restore inlet conditions within the limits of the valve.
Erratic flow of water from the valve	a) Insufficient water supplies. b) Fluctuations in supply pressures/temperatures. c) Adverse effect created by other draw off points on the system.	<ul style="list-style-type: none"> • Stabilise inlet supply conditions.
No flow of water from the valve	a) In-line filters blocked. b) Insufficient supply pressures. c) Debris obstructing valve operation.	<ul style="list-style-type: none"> • Clean filters. • Restore inlet supplies. • Clean debris or scale from valve.
Valve does not shutoff when tested	a) Installation not in accordance with our recommendations. b) The minimum temperature differential not achieved. c) Internal mechanism hindered by debris.	<ul style="list-style-type: none"> • Install as outlined in the instructions. • Raise hot water temperature. • Clean debris or scale from valve.

Safety



- Tempering valves must only be installed by a licensed plumber.
- A minimum temperature differential of 10°C is required between the hot water inlet and the mixed water outlet to ensure correct operation of the thermal shutoff feature.

- Water temperatures higher than 50°C can endanger people.
- The Caleffi 5213 series valve is not to be used in conjunction with instantaneous hot water boilers and systems. Their inclusion may compromise the correct operation of the instantaneous boiler unit.
- Ensure that the valve is supported and that the connecting pipework is not overstressed as breakages can cause harm to people and/or water damage to property.
- In the case of highly aggressive water, in accordance with the current legislation, treat the water before it enters the tempering valve. This will avoid damage to the valve.
- If the tempering valve is not installed, commissioned and maintained properly, according to the instructions contained in this manual, it may not operate correctly and may endanger the user.

Leave this manual for the user.

AUSTRALIAN AGENT

**ALL VALVE INDUSTRIES Pty Ltd
Unit 2 1 Wood Street
NSW 2044 Tempe
AUSTRALIA
Tel. (02) 9558.9911
Fax (02) 9558.9699**

CALEFFI

S.R. 229, n. 25 · I-28010 Fontaneto d'Agogna (NO) · Tel. Int. +39 322 8491 R.A. · Fax +39 0322 863723
Http://www.caleffi.com · E-mail:info@caleffi.com